

Honeywell

7800 SERIES 22-Terminal Universal Subbase

PRODUCT DATA



**Q7800B1003/2003/U
Metal Wall-mount
subbase**



**Q7800A1005/2005/U
Plastic Wall-mount
subbase**

FEATURES

- Quick-mount wiring subbase for all 7800 SERIES Relay Modules and S7830 Expanded Annunciator.
- Allows wiring of control system before installation of relay module.
- Can be panel mounted (Q7800A) or burner or wall mounted (Q7800B).
- Access slots provided for electrical measurement.
- NEMA 1 enclosure.
- Electrical access slot covers provided with Q7800B; available as an option for Q7800A/

APPLICATION

The Q7800A,B is a universal wiring subbase for the 7800 SERIES Relay Modules and Expanded Annunciator (S7830A). The universal wiring subbase provides terminals for field wiring. Knife blade terminals located on the 7800 SERIES Relay Module or S7830A engage the Q7800 bifurcated contacts to make electrical connections.

The Q7800A1005 (2-sided) and Q7800A2005/U subbases are available for panel mounting applications. The Q7800A1003 and Q7800B2003 are available for burner or wall mount applications. Knockouts are provided in the back, top and bottom for conduit connections.



32-000167-01

SPECIFICATIONS

Weight:

Q7800A: 7 ounces.
 Q7800B: 1 pound, 3 ounces.

Dimensions:

See Fig. 1, 2 and 3.

Enclosure:

NEMA 1.

Terminal Screw Torque:

12 pound-inches typical; 13 pound-inches maximum.

Approvals:

Underwriter Laboratories Inc. Component Recognized:
 File no. MP268, Guide no. MCCZ2 (Q7800A),
 Listed: File no. MP268, Guide no. MCCZ (Q7800B).
 Canadian Standards Association Certified: LR95329-3
 (for Q7800A1005 and Q7800A1003 only).
 To meet EN60730 approval, the Q7800 subbase must be
 mounted in a secured panel which meets IP40 class of
 protection.

Accessories:

221779 Electrical Access Slot Covers (supplied with
 Q7800B, optional for Q7800A).

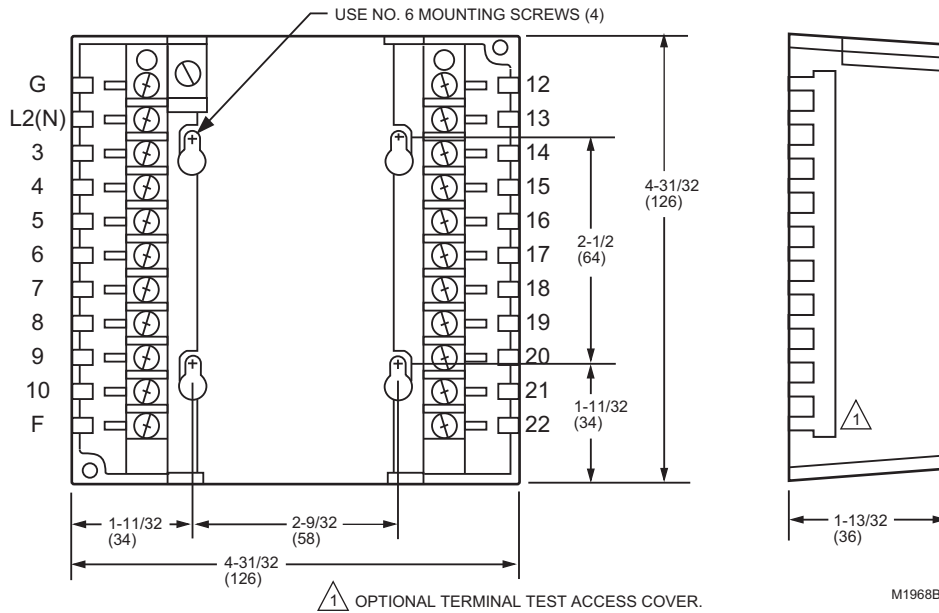

Fig. 1. Top and front view of Q7800A1005 Wiring Subbase (2-sided) with dimensions in in. (mm).

Subbase Model's Compatibly

IMPORTANT

There are now two different versions of the RM7800 Subbases. It is important to note which subbase is compatible with which Relay Modules when supporting repair or replacement.

The Q7800A1005/U and Q7800B1003/U subbases have not changed and are still used with all legacy RM7800 models that have a “1” designation in the model number. For example: RM7800A1012

The Q7800A2005/U and the Q7800B2003/U are new additions to the subbase offering and should be used for all RM7800 models that have a “2” designation in the model number. For example: RM7800A2012. These new subbases are easily identified by the standing Grounding Pin located in the corner. See Fig. 2.

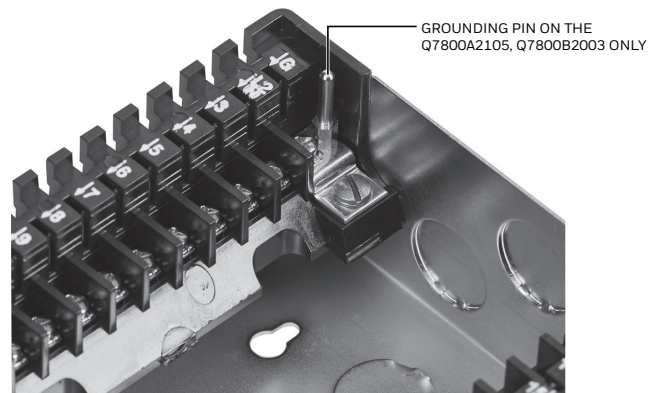

Fig. 2. Series 2000 grounding pin location.

Subbase Compatibility

The Q7800A1005/U (plastic) or Q7800B1003/U (metal) line supports all legacy and new 1000 Series Relay Modules; e.g. RM7840G1014 (which can be identified by a the software revisions levels greater than 5xxx). There are no changes in configuration or mounting with these models.

Series 2000 Subbase

New Subbase models (Q7800A2005/U (plastic) or Q7800B2003/U (metal)) supports all 2000 Series Relay Modules; e.g. RM7840G2014 will also support all new 1000 Series models (SW revision level 5xxx and greater)

IMPORTANT

The 2000 Series models **are not compatible with legacy Relay Modules** as they do not have a hole in the base of the relay module to accommodate the Grounding Pin.

Make sure to check the Relay Model number and check the Subbase compatibly prior to ordering or attempting a new installation or field upgrade.

The Grounding Pin MUST be in place for the 2000 Series Relay Module to operate. If this pin is removed or damaged, the 2000 Series Relay Module will NOT operate and all warranties will be voided.

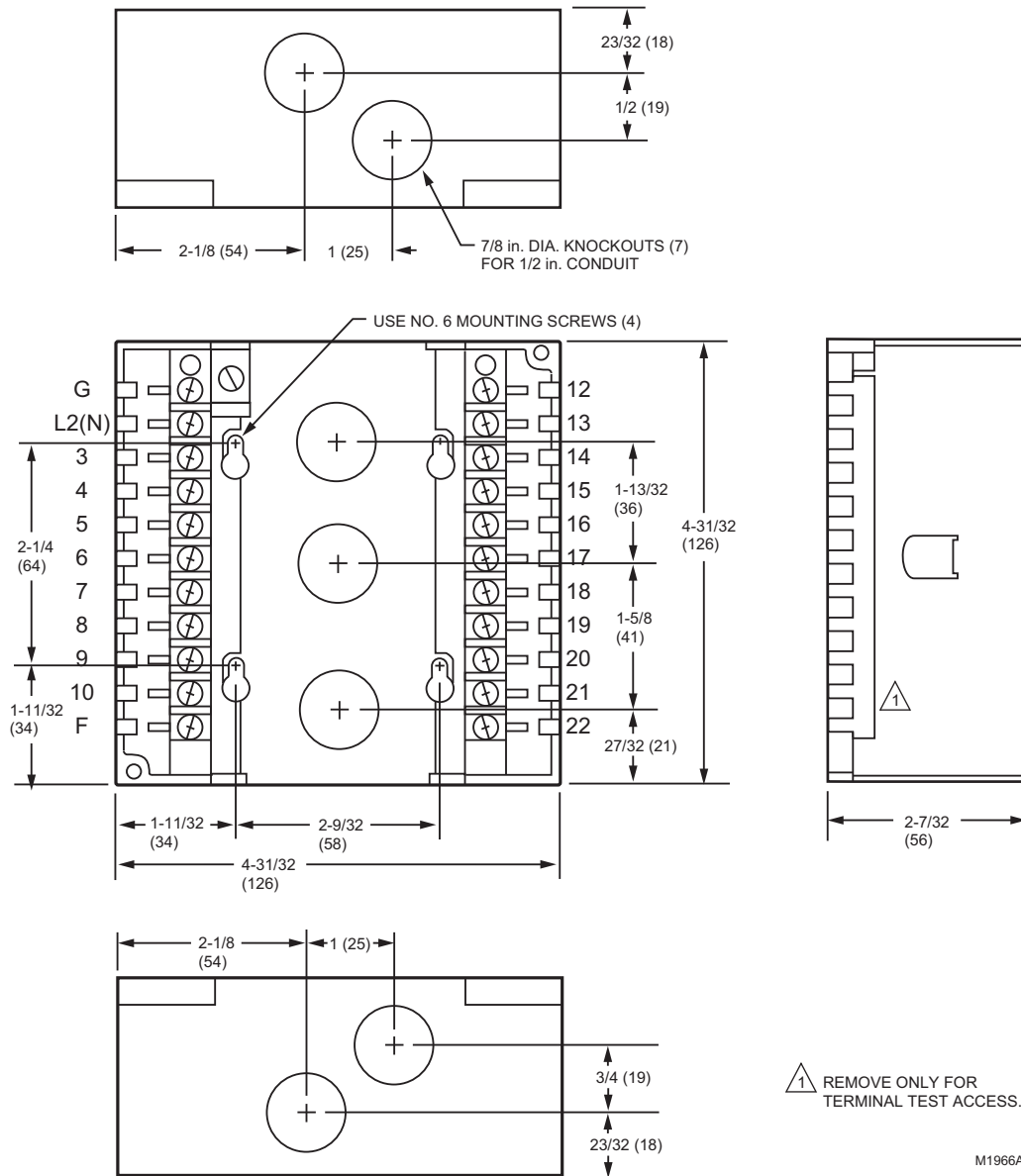

Fig. 3. Top and front view of Q7800B1003 Wiring Subbase (4-sided) with dimensions in in. (mm).

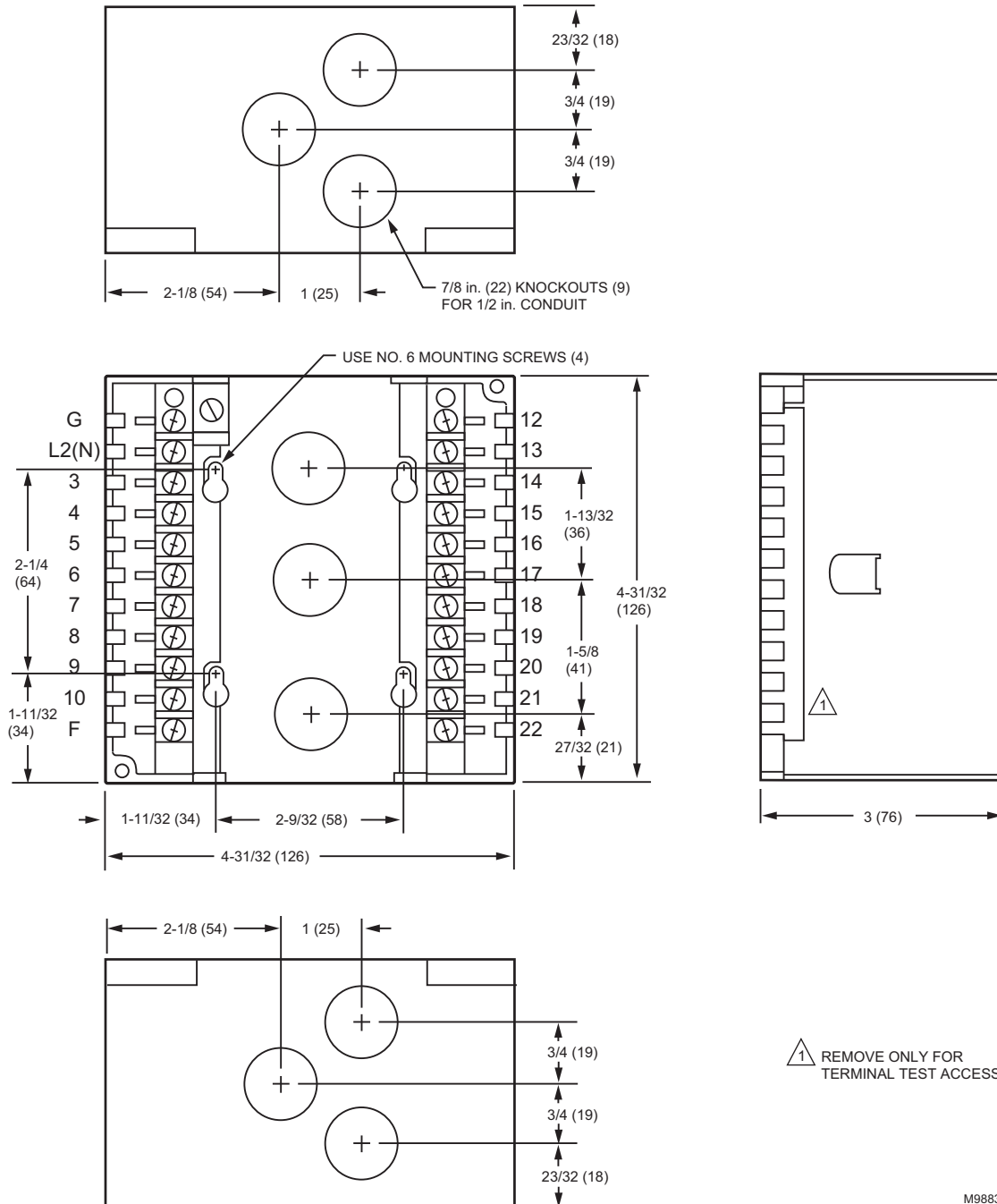

Fig. 4. Top and front view of Q7800B1011 Wiring Subbase (4-sided) with dimensions in in. (mm).

INSTALLATION

When Installing this Product...

1. Read these instructions carefully. Failure to follow them could damage the product or cause a hazardous condition.
2. Check the ratings given in the instructions and on the product to make sure the product is suitable for your application.
3. Installer must be a trained, experienced, Flame Safeguard service technician.
4. Disconnect the power supply before beginning installation to prevent electrical shock and equipment damage. More than one disconnect may be involved.
5. All wiring must comply with applicable local electrical codes, ordinances, and regulations.
6. All wiring must be NEC Class 1 (Line Voltage).
7. After installation is complete, check out product operation as provided in these instructions.

⚠ WARNING

Electrical Shock Hazard.
Can cause serious injury, death or property damage.

Disconnect power supply before beginning installation to prevent electrical shock and equipment damage. More than one disconnect may be involved.

⚠ WARNING

Grounding Pin required for 2000 Series

The Grounding Pin **MUST** be in place for the 2000 Series Relay Module to operate. If this pin is removed or damaged, the 2000 Series Relay Module will **NOT** operate and all warranties will be voided.

Follow the equipment manufacturer instructions if available; otherwise, proceed as follows below.

Mounting

When Mounting the 2000 Series Subbase (Models Q7800A2005/U and the Q7800B2003/U) the Grounding Pin will be located in the upper LH corner, and follows the same mounting procedure as detailed below. See Fig. 2 for Grounding Pin location.

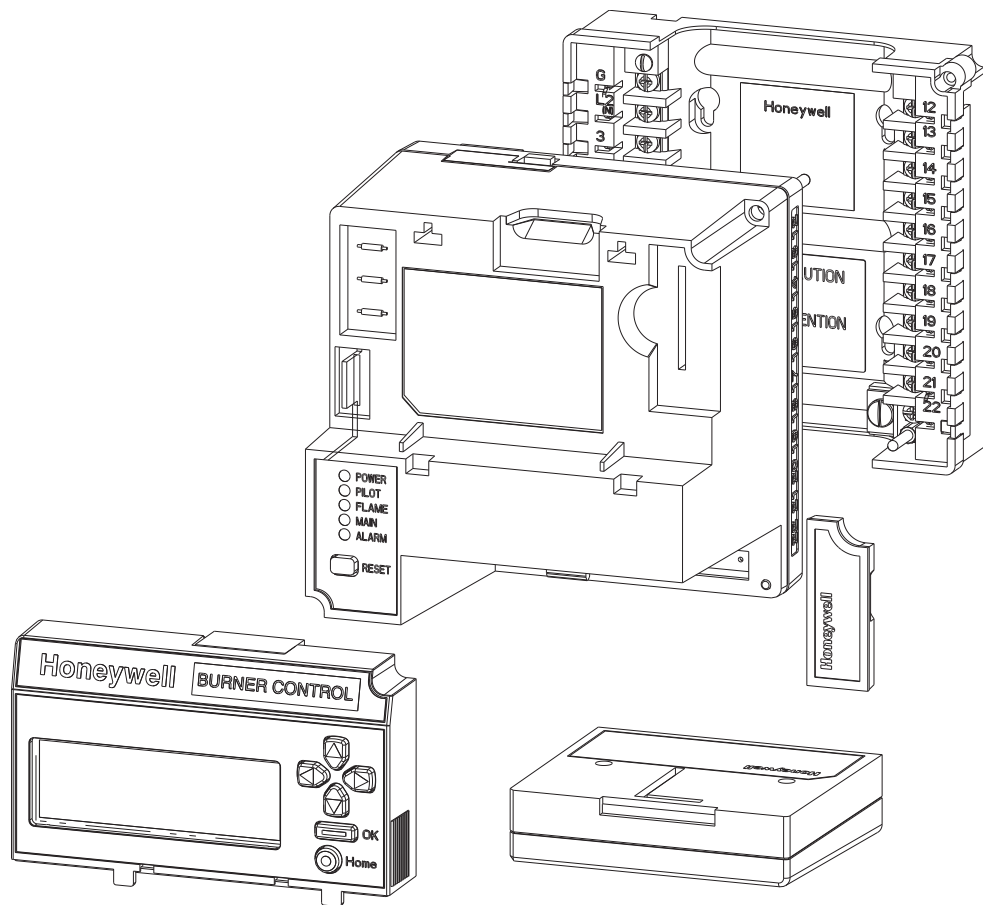

Fig. 5. Mounting.

NOTE: For installation dimensions, see Fig. 1 and 2.

1. Place the subbase in a location within the ambient temperature rating of the 7800 SERIES Relay Module and S7830A being used. Refer to the appropriate Instructions.
2. Mount the subbase in any position except horizontally with the bifurcated contacts pointing down. The standard vertical position is recommended.
3. Select a wall, burner or electrical panel location. Or mount the Q7800 directly in the control cabinet. Be sure to allow adequate clearance for servicing, installation, access or removal of the 7800 SERIES Relay Module, S7830A, Keyboard Display Module, Run/Test switch, flame amplifier signal voltage probes, electrical signal voltage probes and electrical field connections.

IMPORTANT

Do not mount the wiring subbase horizontally with the bifurcated contacts pointing down.

4. For surface mounting, use the back of the subbase as a template to mark the four screw locations. Drill the pilot holes.
5. Insert the mounting screws using four no. 6 screws tightened securely.

WIRING

1. Refer to the equipment manufacturer's wiring information and the appropriate 7800 SERIES Relay Module or S7830A Specifications for correct subbase wiring.
2. Provide overload protection and disconnect means as required. Disconnect the power supply from the main disconnect before beginning installation to prevent electrical shock and equipment damage. More than one disconnect may be involved.
3. All wiring must comply with appropriate electrical codes, ordinances and regulations. Use NEC Class 1 (Line Voltage) wiring.
4. Recommended wire size and type is to use up to two no. 14, 16, or 18 copper conductors TTW60C, THW75C or THHN90C, 600 volt insulation wire for all Line Voltage terminals. For high temperature installations, use wire selected for a temperature rating above the noted maximum operating temperature. The flame detector leadwires should be moisture resistant.
 - a. For the ignition leadwire, use Honeywell specification no. R1061012 Ignition Cable or equivalent. (This wire is rated at 350°F (177°C) for continuous duty, and up to 500°F (260°C) for intermittent use. It has been tested to 25,000 volts.)
 - b. For the flame detector F leadwire, use Honeywell specification no. R1298020 or equivalent. (This wire is rated at 400°F (204°C) for continuous duty. It is tested for operation up to 600 volts and breakdown up to 7500 volts.)
 - c. For ignition installation in a contaminating environment, use Honeywell specification no. R1239001 High Tension Ignition Cable or equivalent. (This wire is resistant to severe conditions of oil, heat and corona, and is tested to withstand high voltages up to 25,000 Vrms in a salt bath for one minute without breakdown. It is rated at 200°F (93°C) for continuous duty, and up to 350°F (177°C) for intermittent use.)
5. Recommended grounding practices:
 - a. Each 7800 SERIES Relay Module or S7830A will have an earth ground terminal G that must be grounded to the metal control panel with wire as short as practical. Each ground wire must be capable of carrying a fault current equal to the rating of the protective fuse (15 amperes maximum, type SC or equivalent, fast-blow fuse); a number 14 copper conductor is adequate.
 - b. The earth ground provides a connection between the subbase and the control panel or the equipment. The earth ground wire must be capable of conducting the current to blow the 15A maximum, type SC or equivalent, fast-blow fuse (or breaker) in event of an internal short circuit. The 7800 SERIES Relay Module needs a low impedance ground connection to the equipment frame which, in turn, needs a low impedance connection to earth ground. For a ground path to be low impedance at RF frequencies, the connection must be made with minimum length conductors that have maximum surface areas. Wide straps or brackets are preferred rather than leadwires. Be careful to ensure that mechanically tightened joints along the ground path, such as pipe or conduit threads or surfaces held together with fasteners, are free of nonconductive coatings and have corrosion-protected mating surfaces.
6. Recommended wire routing for flame detector leadwires:
 - a. Do not run high voltage ignition transformer wires in the same conduit with the flame detection wiring.
 - b. Do not route scanner wires in the same conduit with line voltage circuits.
 - c. Scanner wiring not utilizing armor cable should be enclosed in metal cable or conduit.
 - d. Follow directions in Flame Detector Instructions.
7. Maximum wire lengths for flame detector leadwires are limited by the flame signal strength.
8. Make sure that loads do not exceed terminal ratings; refer to the labels on the 7800 SERIES Relay Module, or S7830A, or ratings in the 7800 SERIES Relay Module or S7830A Specifications.
9. Check the power supply circuit. The voltage and frequency tolerance must match those of the 7800 SERIES Relay Module or S7830A. Do not connect the 7800 SERIES Relay Module or S7830A to a power supply circuit that is subject to line voltage variations, such as would occur with on-off switching of heavy loads. A separate power supply circuit may be required for the 7800 SERIES Relay Module or S7830A. Add the required disconnect means and overload protection.
10. Check all the wiring circuits and complete a *Static Checkout* according to the 7800 SERIES Relay Module or S7830A Specifications before installing the 7800 SERIES Relay Module or S7830A on the subbase.
11. Install the 7800 SERIES Relay Module or S7830A.
12. Restore power to the panel.

IMPORTANT

Do not run high voltage ignition transformer wires in the same conduit with the flame detector wiring.

IMPORTANT

Make sure no subbase wiring is projecting beyond the terminal blocks. Tuck wiring in against the back of the subbase so it does not interfere with the knife blade terminals or bifurcated contacts.

CHECKOUT

After installation, perform a complete checkout of the system. Follow information supplied by equipment manufacturer and instructions furnished with the 7800 SERIES Relay Module or S7830A.

SERVICE NOTE:

Voltage checks can be accomplished by using the electrical access slots on the sides of the Q7800A,B. Remove the electrical access slot covers on the Q7800B before making the voltage checks.



WARNING

Electrical Shock Hazard.

Can cause serious injury, death or property damage.

Always replace the electrical access slot covers on the Q7800B after performing voltage checks or anytime they are removed, to prevent the possibility of electrical shock.

For More Information

The Honeywell Thermal Solutions family of products includes Honeywell Combustion Safety, Eclipse, Exothermics, Hauck, Kromschröder and Maxon. To learn more about our products, visit ThermalSolutions.honeywell.com or contact your Honeywell Sales Engineer.

Honeywell Process Solutions

Honeywell Thermal Solutions (HTS)
1250 West Sam Houston Parkway
South Houston, TX 77042
ThermalSolutions.honeywell

® U.S. Registered Trademark
© 2018 Honeywell International Inc.
32-00167-01 M.S. 04-18
Printed in United States

Honeywell