

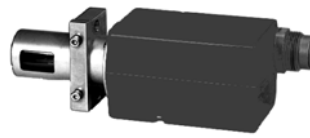

QRA7... with clamp



QRA10...



QRA53..., QRA55... with clamp

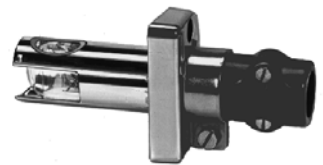

QRA2... with clamp

## Flame Detectors

**QRA2...**  
**QRA10...**  
**QRA53...**  
**QRA55...**  
**QRA73...**  
**QRA75...**

---

The UV flame detectors are designed for use with Siemens burner controls, for the supervision of gas or oil flames.

The QRA... and this Data Sheet are intended for use by OEMs which integrate the flame detectors in their products.

## Use

The flame detectors are used for the supervision of gas flames, yellow- or blue-burning oil flames and for ignition spark proving.

Flame detector	For use with burner control type	Operating mode
QRA2..., QRA10...	LGB2... / LGB4... with AGQ1... LFL... LFE1... LFE10... LMG... with AGQ2... LME21... / LME22... / LME39... with AGQ3... LMV2... / LMV3... LMV5... with AGQ1...	Intermittent
QRA53..., QRA55...	LGK16... LGI16...	Continuous operation
QRA73..., QRA75...	LMV5...	Continuous operation

## Warning notes



**To avoid injury to persons, damage to property or the environment, the following warning notes must be observed!**

- All activities (mounting, installation and service work, etc.) must be performed by qualified staff
- Before making any wiring changes in the connection area, completely isolate the plant from mains supply (all-polar disconnection). Ensure that the plant cannot be inadvertently switched on again and that it is indeed dead. If not observed, there is a risk of electric shock hazard.
- Ensure protection against electric shock hazard by providing adequate protection for the terminals. If this is not observed, there is a risk of electric shock
- Each time work has been carried out (mounting, installation, service work, etc.), check to ensure that wiring is in an orderly state. If this is not observed, there is a risk of electric shock
- Halogen lamps, welding equipment, special lamps or ignition sparks may produce sufficient radiation for the detector's UV cell to ignite. X-rays and gamma radiation can also generate erroneous flame signals. If this is not observed, there is a risk of loss of safety functions
- Fall or shock can adversely affect the safety functions. Such units must not be put into operation, even if they do not exhibit any damage. If this is not observed, there is a risk of loss of safety functions and a risk of electric shock

## Mounting notes

- Ensure that the relevant national safety regulations are complied with

## Installation notes

- Always run the high-voltage ignition cables separate while observing the greatest possible distance to the detector and to other cables

## Electrical connection of the flame detector

It is important to achieve practically disturbance- and loss-free signal transmission:

- Never run the detector cable together with other cables
  - Line capacitance reduces the magnitude of the flame signal
  - Use a separate cable
- Observe the permissible lengths of the detector cable (refer to «Technical data» in the Data Sheet of the relevant burner control)

**Commissioning notes**

- Trouble-free burner operation is ensured only when the intensity of UV radiation at the detector's location is high enough for the detector's UV cell to ignite during each half wave. The **intensity of UV radiation** at the detector's location is **checked through measurement of the detector current**

Measuring circuit for QRA2..., QRA10..., QRA5...series D and QRA5...series G

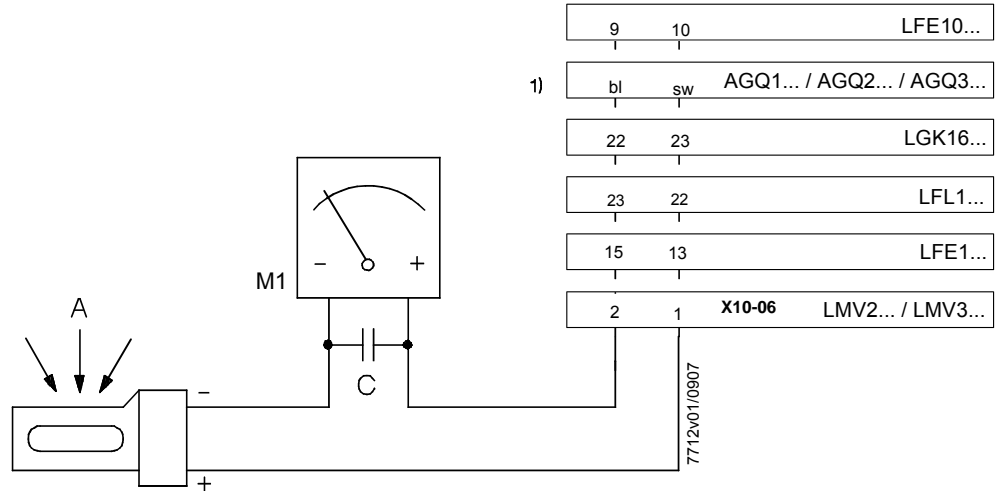

**Legend**

- 1) Connection of micro-ammeter across AGQ1... / AGQ2... / AGQ3... adapter and flame detector
- A Incidence of radiation
- M Micro-ammeter (DC), internal resistance  $\leq 5000 \Omega$
- C Electrolytic capacitor 100...470  $\mu\text{F}$ , DC 10...25 V

Measuring circuit for QRA5... up to the C-series and QRA5...series E

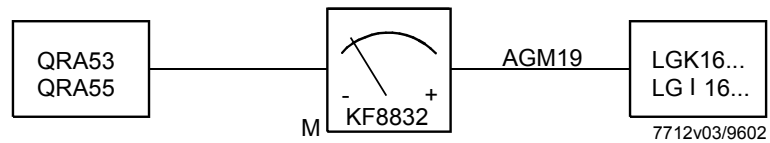

**Note!**  
The KF8832 flame detector current measuring device must not be used in continuous operation!

Minimum detector current values required:

Refer to the Data Sheet of the relevant burner control or to the Operating Instructions of the KF8832.

Measuring circuit for QRA7...

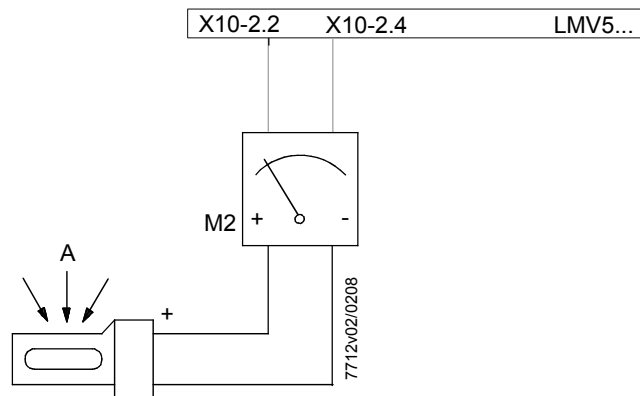

- M2 Voltmeter direct current voltage  
Measurement range 0...10V  
Internal resistance  $R_i \geq 10\text{M}\Omega$

## Certificates

---



Conformity to EEC directives  
- Electromagnetic compatibility EMC (immunity)  
- Low-voltage directive

2004/108/EC  
2006/95/EC



ISO 9001: 2010  
Cert. 00739



ISO 14001: 2010  
Cert. 38233

## Service notes

---

- Use the KF8832 service unit for short periods of time only

## Disposal notes

---



The flame detector contains electrical and electronic components and must not be disposed of together with domestic waste.  
Local and currently valid legislation must be observed.

## Mechanical design

Flame detectors  
QRA2... Plastic housing, metalized to prevent static charging caused by the air flow from the fan. For mounting direct on the burner. The detectors can be supplied with or without securing flange (version 4 241 8855 0) and clamp (refer to «Type summary»).

Flame detectors  
QRA10... Die-cast aluminium housing with a 1 in. mounting coupling (D) and connection facility for cooling air. The housing of this detector has a bayonet fitting which allows it to be secured either directly to the 1 in. mounting coupling or to the AGG06 glass holder. The 1 in. mounting coupling can be screwed to a viewing tube or to the AGG07 ball head. The Pg cable gland can be removed and replaced, if some other detector cable shall be used.

Flame detectors  
QRA5..., QRA7... The detector's UV cell is located behind a swiveling shutter at the front end of the detector tube which is flanged to the housing. A quartz-glass window protects the tube and the shutter against dirt. The detector's housing accommodates a stepper motor to drive the shutter and the electronics to control the shutter. Using the AGG16.C adapter, this flame detectors can be mounted either directly on the burner, on a viewing tube or on a combustion chamber viewing hole.

Plug AGM19 AGM19 complete with cable for the connection of QRA53... and QRA55... flame detectors.

Adapter AGG16.C AGG16.C for QRA53..., QRA55..., made of die-cast aluminium with a 1 in. mounting coupling. The 1 in. mounting coupling (D) is attached to the housing with a bayonet fitting.

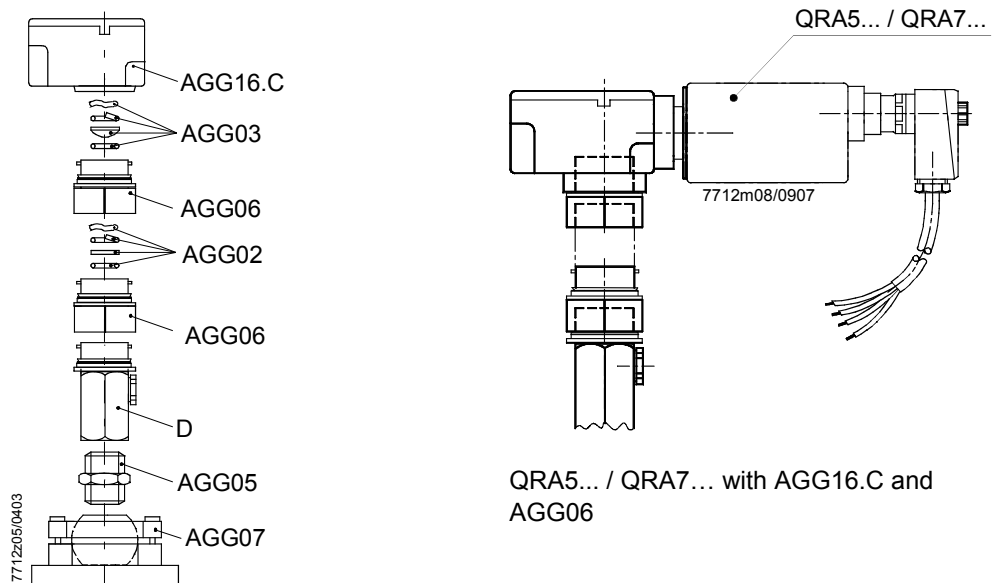

**Note!**  
 AGG03 or AGG02 can also be fitted in the 1 in. mounting coupling (D) of the AGG16.C (or QRA10...). An adapter combination with AGG06 glass holder, mounting coupling and ball joint for QRA53..., QRA55..., QRA7... and QRA10... is possible.

Connector AGM23 Connector AGM23 with cable for the electrical connection of flame detector QRA7...

Connector AGM23U Connector AGM23 with wires for the electrical connection of flame detector QRA7... in US design

## Mechanical design (cont'd)

Glass and quartz-glass lens holder AGG06

The glass and quartz-glass lens holder AGG06 serves for holding the AGG03 lens and the AGG02 heat insulation glass.

The lens is used to increase the sensitivity, and the heat insulation glass provides protection against high temperatures, thus extending the life of the UV cell.

The AGG06 also allows various combinations of lens, heat insulation glass and 1 in. mounting coupling.

When using the lens and the heat insulation glass, the AGG06 with the lens must be mounted as close as possible to the flame detector.

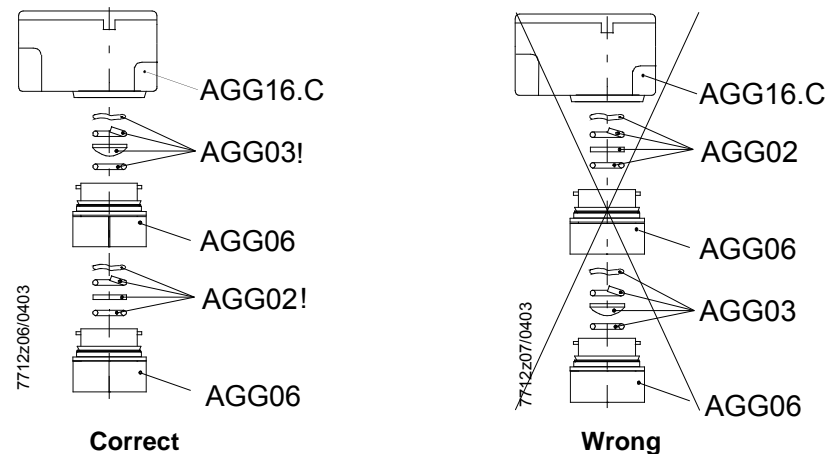

AGG06 has a bayonet fitting with which it is attached either to the housing of the AGG16.C or to the housing of the QRA10... and the 1 in. mounting coupling.

By undoing the bayonet fittings on both sides, the AGG06 glass holder(s) can be easily detached from the combination of QRA10... or AGG16.C and QRA53... or QRA55....

This facilitates straightforward cleaning of the glass or lens without having to remove them from the AGG06 glass holder.

The intermediate rings are used for the smooth running of the bayonet fittings, especially where – after removal of the flame detector – the hole to the combustion chamber serves as a viewing tube.

By fitting the intermediate ring to the appropriate bayonet connection, the combination can be undone where required by rotating the housing of the QRA10... or AGG16.C

Quartz-glass lens AGG03

AGG03 with spring washer and O-ring for increasing the sensitivity.

Heat insulation glass AGG02

AGG02 with spring washer and O-ring, offering the same mounting choices as AGG03. This heat insulation glass is required on applications where the temperature at the flame detector exceeds 80 °C.

Mounting coupling (D)

Using the bayonet fitting, the 1 in. mounting coupling can be attached either to the AGG06, the AGG16.C or the QRA10... flame detector. The mounting coupling is supplied with the QRA10... or AGG16.C.

Nipple AGG05

1in. nipple AGG05 for connecting the 1in. mounting coupling (D) to the AGG07 ball head.

Ball head AGG07

AGG07 with 1in. internal thread. Connection on AGG05 and for use with the 1in. mounting coupling and AGG06. The AGG07 is used for mounting on a rigid surface, such as the boiler wall. It facilitates optimum adjustment of the viewing angle.

## Type summary

Flame detectors					
Type reference	Sensitivity	Flange and clamp	Terminal cover	Spare UV tube	
<b>QRA2</b>	Normal	Without	Black	AGR4 502 1131 0	
<b>QRA2(1)</b>		With			
<b>QRA2.9<sup>2)</sup></b>		Without			
<b>QRA2M</b>	High	Without	Green	AGR4 502 4065 0	
<b>QRA2M(1)</b>		With			
<b>QRA10.C</b>	Normal	---	---	AGR4 502 1131 0	
<b>QRA10M.C</b>	High	---	---	AGR4 502 4065 0	

Type reference	Sensitivity	Detector tube length	Mains voltage	Spare UV tube
<b>QRA53.C27</b>	normal	125 mm	AC 220...240 V	AGR4 502 4065 0
<b>QRA53.C17</b>			AC 100...110 V	
<b>QRA53.D27</b>	high	125 mm	AC 220...240 V	
<b>QRA53.D17</b>			AC 100...110 V	
<b>QRA53.E27</b>	normal	125 mm	AC 220...240 V	
<b>QRA53.E17</b>			AC 100...110 V	
<b>QRA53.G27</b>	high	125 mm	AC 220...240 V	
<b>QRA53.G17</b>			AC 100...110 V	
<b>QRA55.C27</b>	normal	69 mm	AC 220...240 V	
<b>QRA55.C17</b>			AC 100...110 V	
<b>QRA55.D27</b>	high	69 mm	AC 220...240 V	
<b>QRA55.D17</b>			AC 100...110 V	
<b>QRA55.E27</b>	normal	69 mm	AC 220...240 V	
<b>QRA55.E17</b>			AC 100...110 V	
<b>QRA55.G27</b>	high	69 mm	AC 220...240 V	
<b>QRA55.G17</b>			AC 100...110 V	

Type reference	Sensitivity	Detector tube length	Mains voltage	Spare UV tube
<b>QRA73.A27</b>	normal	125 mm	AC 230 V +10 / -15 %	AGR4 502 4065 0
<b>QRA73.A17</b>			AC 120 V +10 / -15 %	
<b>QRA75.A27</b>	normal	69 mm	AC 230 V +10 / -15 %	
<b>QRA75.A17</b>			AC 120 V +10 / -15 %	



### Note!

Mounting Instruction for replacing of spare UV tube, refer to 4 319 9513 0 (M7712.5)!



### Note!

All QRA5... and QRA7... are delivered complete with clamp. Use of the detector requires a connecting cable **AGM19 / AGM23 / AGM23U** (refer to «Accessories» for QRA5... / QRA7...).

Accessories for QRA2... and QRA5... and QRA7... when ordered as single items

Part	For use with	Part number
Flange <sup>3)</sup> rounded	QRA2...	<b>4 241 8855 0</b>
Flange straight	QRA2...	<b>4 241 8898 0</b>
Clamp <sup>3)</sup>	QRA2...	<b>4 199 8806 0</b>
Clamp for direct mounting	QRA5... / QRA7...	<b>4 199 1034 0</b>

Accessories for QRA5... / QRA7...

Type reference	Description
<b>AGG16.C</b>	Adapter for flame detector mounting QRA53... and QRA55... / QRA7...
<b>AGM19</b>	Connecting cable (2 m) with plug for QRA53..., QRA55...
<b>KF8832</b>	Unit for measuring the detector current with QRA53... and QRA55..., recommended for use with detector types up to the C-series
<b>AGM23</b>	Connecting cable 2 m with connector for QRA7...
<b>AGM23U</b>	Connecting cable 4 m with connector for QRA7... US design

## Type summary (cont'd)

Accessories for  
QRA10... and AGG16.C

Type reference	Description
<b>AGG02</b>	Heat insulation glass with spring washer and O-ring
<b>AGG03</b> <sup>1)</sup>	Quartz-glass lens with spring washer and O-ring
<b>AGG05</b>	1 in. nipple
<b>AGG06</b>	Glass and quartz-glass lens holder with intermediate ring
<b>AGG07</b>	Ball head with 1 in. internal thread, swivel range 13°

<b>AGG08</b>	IP65-kit for QRA10... for different types of cable diameter								
									
<table border="1"> <thead> <tr> <th>Cable sealing element Ø in mm</th> <th>Color</th> </tr> </thead> <tbody> <tr> <td>4...6.5 mm</td> <td>Yellow</td> </tr> <tr> <td>6.5...9.5</td> <td>Black</td> </tr> <tr> <td>9...15</td> <td>Red</td> </tr> </tbody> </table>		Cable sealing element Ø in mm	Color	4...6.5 mm	Yellow	6.5...9.5	Black	9...15	Red
Cable sealing element Ø in mm	Color								
4...6.5 mm	Yellow								
6.5...9.5	Black								
9...15	Red								



## Legend

- 1) For detectors of the B-series, lens AGG01 is available
- 2) With heat-resistant housing for ambient temperatures up to 200 °C (short-time, up to a few seconds)
- 3) Supplied with QRA2...(1) types
- 4) Supplied with QRA5... and QRA7... types

## Ordering

When ordering, please give type references according to «Type summary».

## Technical data

General detector data	Average life of UV cell	Approx. 10,000 hours at max. 50 °C, higher ambient temperatures reduce considerably the cell's life
	Perm. combustion chamber pressure	
	- QRA10...	Max. 50 mbar
	- QRA10... + AGG03 or AGG02	Max. 500 mbar
	Degree of protection	
	- QRA2...	IP40
	- QRA10...	IP54 (IP65 with AGG08)
	- QRA5x.C... / QRA5x.D...	IP54
	- QRA5x.E... / QRA5x.G...	IP65
	- QRA7...	IP65
	Mounting position	Optional
	Weight	
	- AGG01	Approx. 10g
	- AGG02	Approx. 10g
	- AGG03	Approx. 10g
- AGG05	Approx. 170g	
- AGG06	Approx. 160g	
- AGG07	Approx. 1330g	
- AGG16.C	Approx. 650g	
- QRA2...	Approx. 46g	
- QRA10...	Approx. 740g	
- QRA10... + AGG03	Approx. 750g	
- QRA5x.C..., QRA5x.D...	Approx. 600g	
- QRA5x.E..., QRA5x.G...	Approx. 700 g	
- QRA7...	Approx. 700g	
Ignition cable (only QRA2...)	2 x 0.75 mm <sup>2</sup> ; 5.1 mm dia.	
Environmental conditions	<b>Storage</b>	DIN EN 60721-3-1
	Climatic conditions	Class 1K3
	Mechanical conditions	Class 1M2
	Temperature range	-20...+60 °C
	Humidity	<95 % r.h.
	<b>Transport</b>	DIN EN 60721-3-2
	Climatic conditions	Class 2K2
	Mechanical conditions	Class 2M2
	Temperature range	-20...+60 °C
	Humidity	<95 % r.h.
	<b>Operation</b>	DIN EN 60721-3-3
	Climatic conditions	Class 3K3
	Mechanical conditions	Class 3M3
	Temperature range	-20...+60 °C
	Humidity	<95 % r.h.



### Caution!

Condensation, formation of ice and ingress of water are not permitted!

## Function

With this type of flame supervision, the UV radiation emitted by gas or oil flames is used to generate the flame signal.

The radiation detector consists of a UV-sensitive cell with 2 electrodes, which ignite when illuminated with radiation in the 190...270 nm range of the spectrum, thereby triggering a current in the flame detector circuit.

The UV cell does not respond to glowing firebrick in the combustion chamber, daylight or light from boiler room illumination.

QRA2...

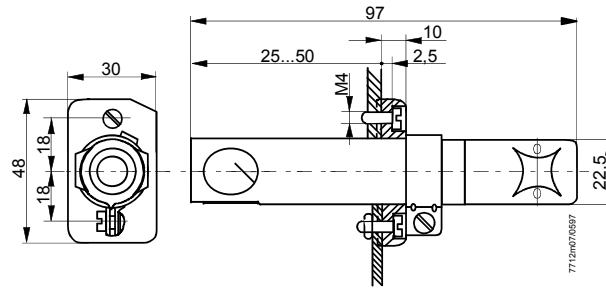

QRA10...

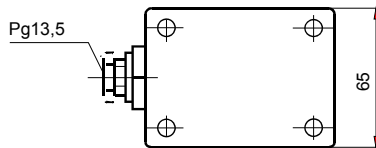
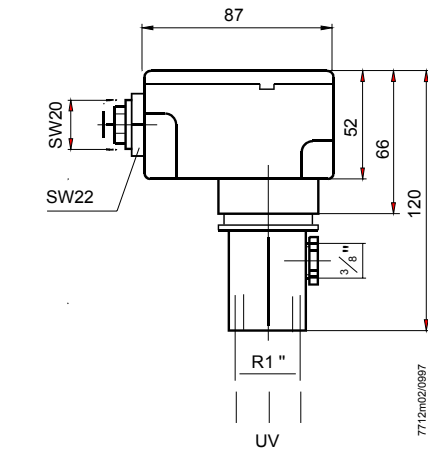

**Dimensions (cont'd)**

Dimensions in mm

**Incidence of radiation**

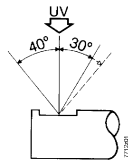

**QRA5xC... /  
QRA5xD...**

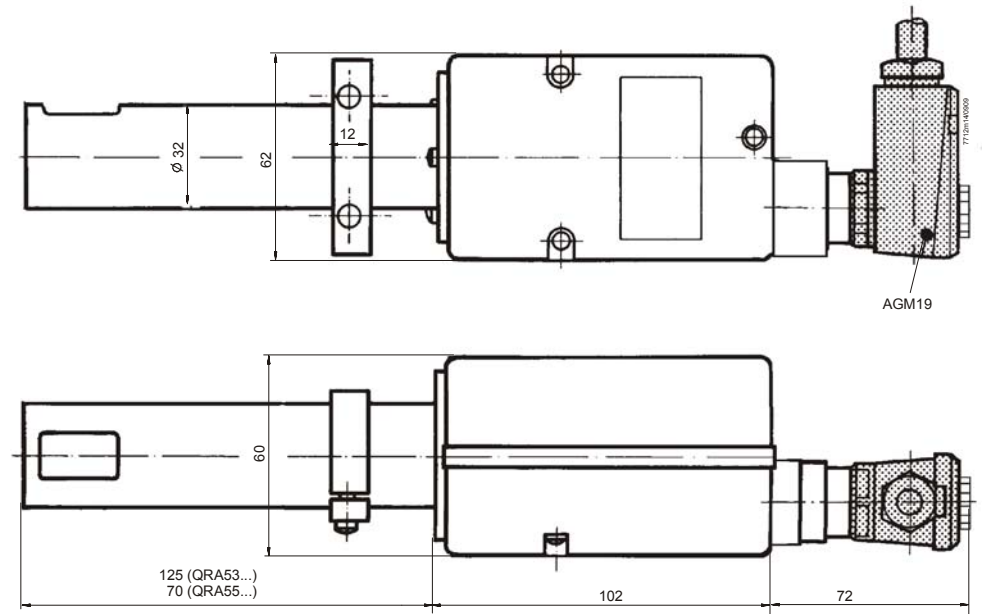

**QRA5x.E... /  
QRA5x.G...**

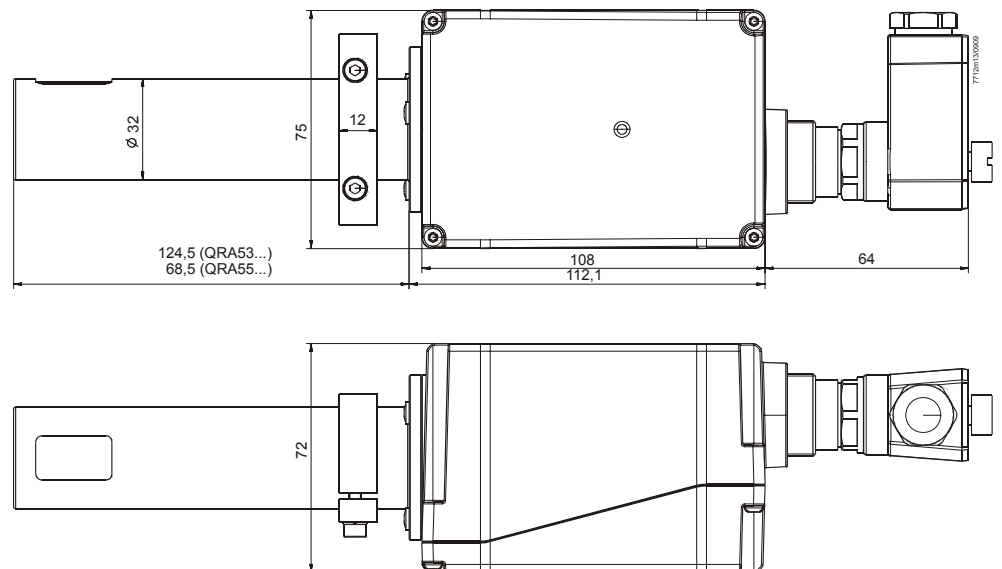

Dimensions (cont'd)

Dimensions in mm

QRA5... with AGG05, AGG06, AGG07, AGG16.C and AGM19

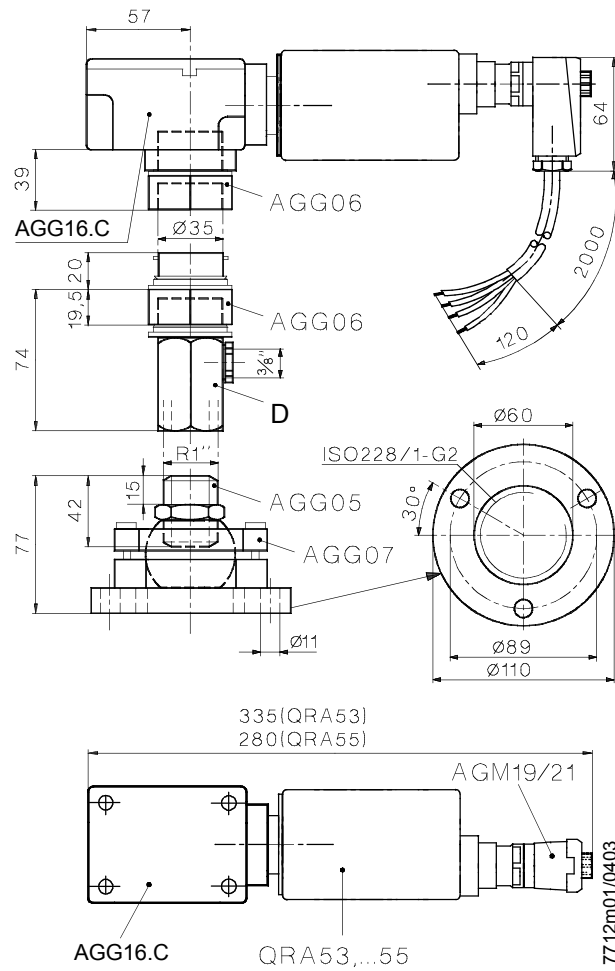

Dimensions (cont'd)

Dimensions in mm

**QRA7... with AGM23**

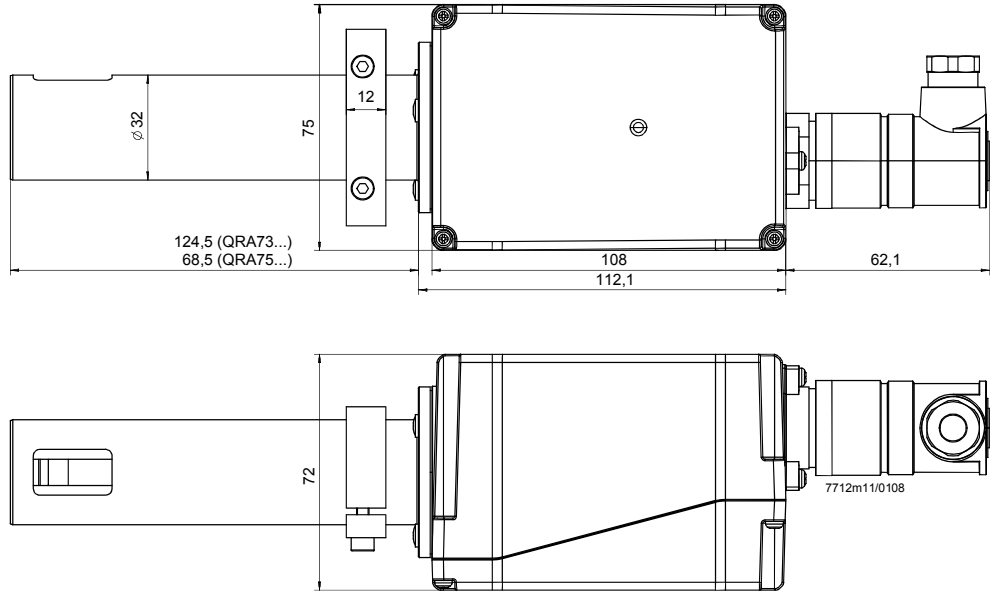

**QRA7... with AGM23U**

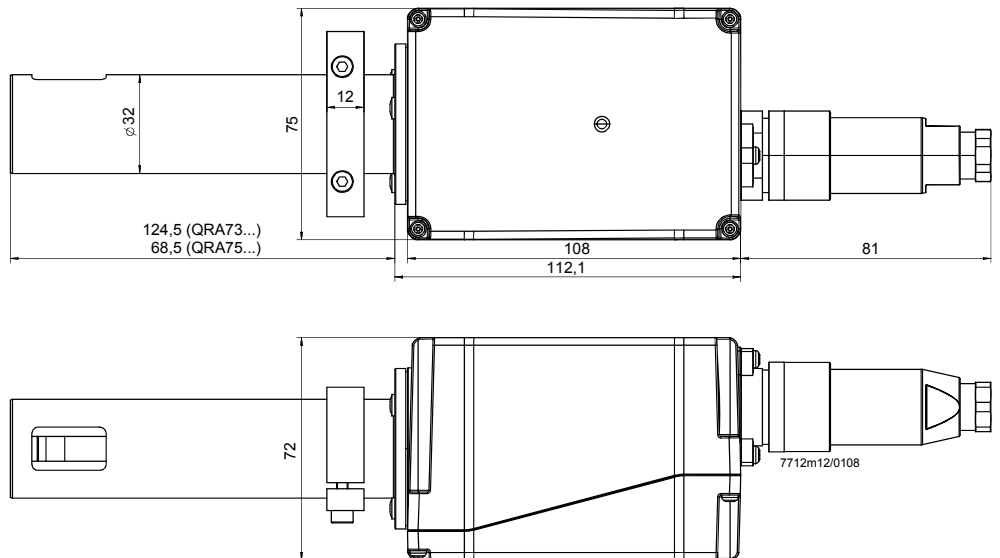

**Dimensions (cont'd)**

Dimensions in mm

**Accessories** (Supplied with QRA5... and QRA7... types)

Clamp for direct mounting on the burner or the AGG16.C

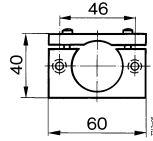

AGG02

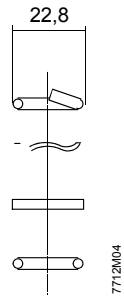

AGG03

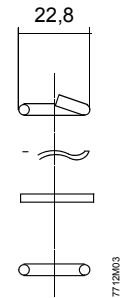

4 241 88550

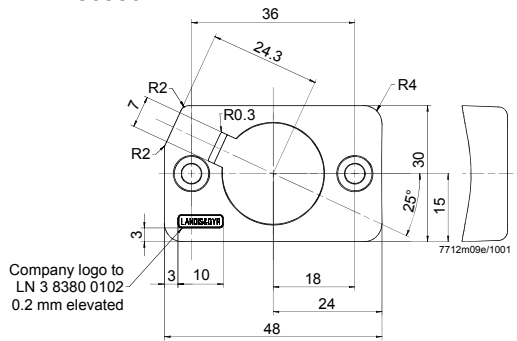

4 241 8898 0

