



Warrick® Series 26M Controls Installation and Operation Bulletin

This bulletin should be used by experienced personnel as a guide to the installation of series 26M controls. Selection or installation of equipment should always be accompanied by competent technical assistance. We encourage you to contact Gems Sensors or its local representative if further information is required.

Specifications

Control Design: Solid State components enclosed in clear lexan plug-in style housing. Housing carries no NEMA ratings.

Contact Design: SPDT (1 form C): One normally open (N.O.) and one normally closed (N.C.) powered contacts.

Contact Ratings: 10 A @ 120,240 VAC resistive (120°F), 1A @ 120, 240 VAC resistive (150°F), 1/3 H.P. @ 120, 240 VAC (120°F)

Contact Life: Mechanical- 5 million operations Electrical- 100,000 operations minimum at rated load.

Supply Voltage: 120, 240 or 24 VAC models: +10% -15% 50/60 Hz. 208/240 model: 187 Vmin to 255 Vmax. VAC 50/60Hz

Supply Current: Relay energized at 4.4 VA

Secondary Circuit: 12 VAC RMS Voltage on probes. 1.5 milli-amp Current.

Sensitivity: Models operate from 4.7K to 100K maximum specific resistance.

Temperature: -40 TO 150°F ambient

Terminals: All connections #6-32 screw type terminals with pressure clamps.

Time Delays: Standard – LLCO probe, 3 seconds standard for lowering level.

Listings: U.L. limit control recognition (353). 240 and 208 volt units are not U.L. limit control recognized.

Installation

1. Install octal socket in appropriate enclosure using two #6 or #8 metal screws.

1A. Install rail mount socket on appropriate rail (DIN mount) in appropriate enclosure if applicable.

2. Wire control per wiring diagram, following N.E.C. and local codes

3. Install control module in socket.

Sensitivities vs Maximum Probe Wire Distance*

SENSITIVITY CHARACTER	SENSITIVITY (KOHMS)	DISTANCE (FT)
A	4.7	900
B	10	600
C	26	250
D	50	100
E	100	50

* Based on type MTW or THHN wire, #14 or #16 Awg

Dimensional Diagram

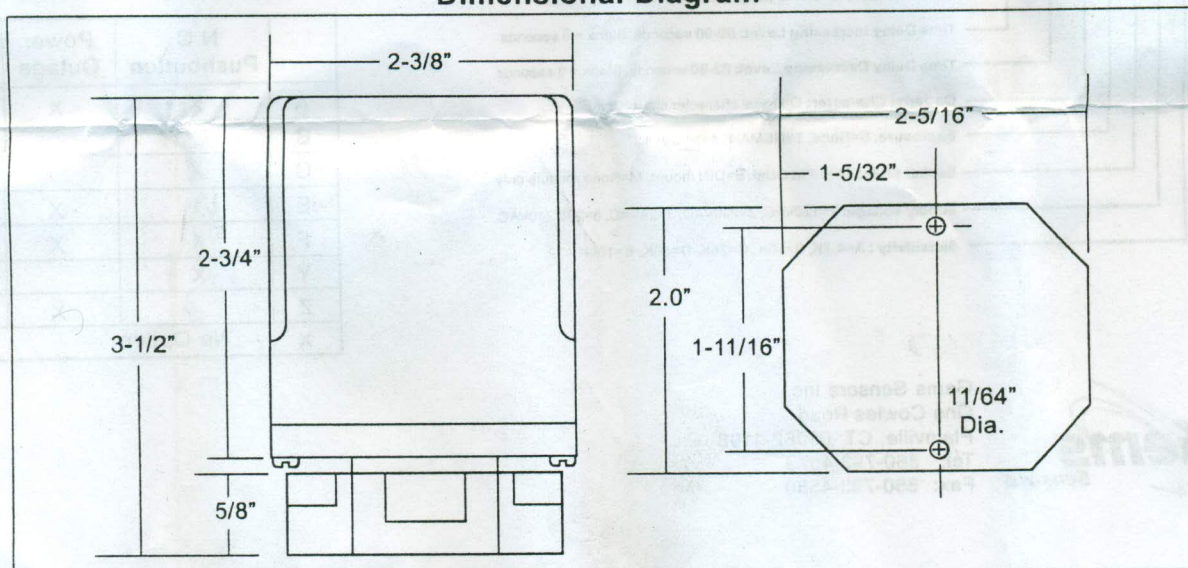

Wiring Diagram

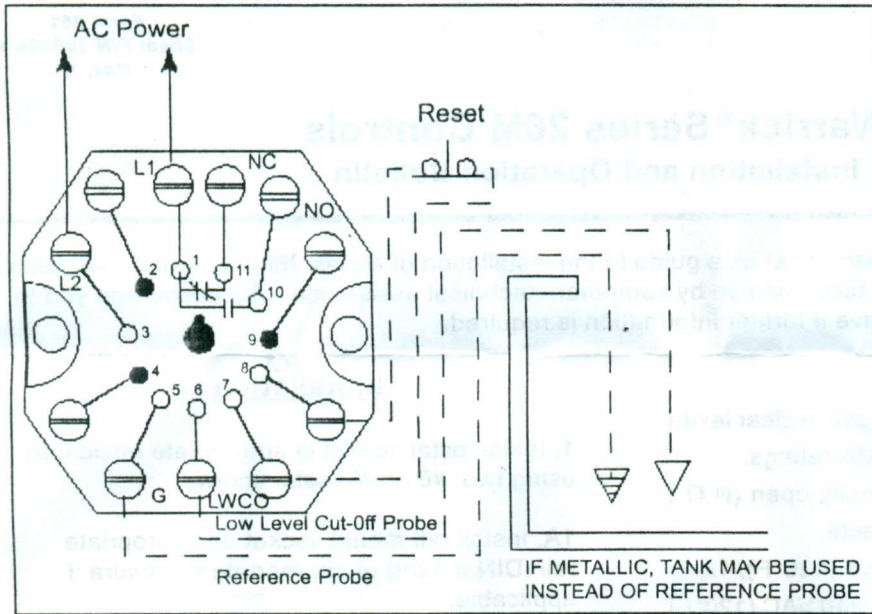

Options:

Automatic Reset: (Reset terminals not used): When the liquid rises to the electrode on terminal 6, the control energizes, changing state of the load contacts. (LED will be lit) The control remains energized until the liquid level recedes below electrode on terminal 6. The control then de-energizes, (LED will not be lit) returning load contacts to original state. Unless otherwise specified, there is a three second time delay on decreasing level. Liquid must be below probe on terminal 6 for a full three seconds before control de-energizes.

Manual Reset: (Normally closed pushbutton installed across terminals #7 and #8): When the liquid rises to the electrode on terminal 6, the control will remain de-energized until the pushbutton is depressed. The control will then energize, (LED will be lit) changing the state of the contacts. The control remains energized until

the liquid level recedes below electrode on terminal 6. The control then de-energizes, (LED will not be lit) returning load contacts to their original state. Unless otherwise specified, there is a three second time delay on decreasing level. Liquid must be below probe on terminal 6 for full three seconds before control de-energizes.

Manual Reset with Optional Power Outage Feature: (Normally closed pushbutton across reset terminals) Control will ignore power loss to control. With liquid above electrode on terminal 6, a power outage will cause the control to de-energize, but will automatically energize upon return of power. However, loss of liquid will cause control to de-energize and remain so until liquid again rises to electrode and pushbutton is depressed.

Dirty Electrode Detection: The LED will flash every half-second once the probe resistance reaches a value greater than the nominal control sensitivity rating. The relay state will not change until it exceeds the nominal sensitivity by more than 25% (typically) at nominal input voltage. At which time the LED and relay contact return to the dry state. Such a condition may suggest electrode maintenance is required.

Test Feature Allows LLCO circuit to be tested. Holding down the reset button for 3 seconds will allow the LLCO circuit to trip which simulates the loss of water, without the need of draining the water level in the boiler. The control will return to normal operation once the reset button is pressed a second time.

26M X X X X X X X X X

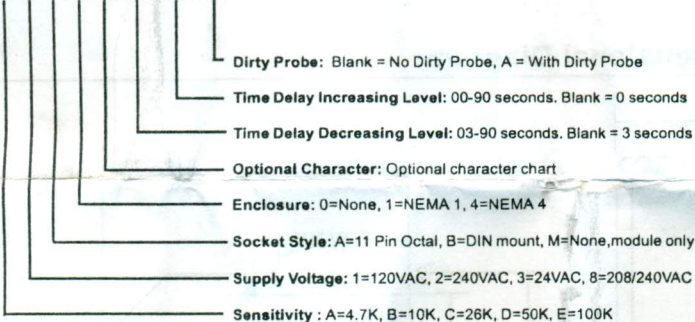

Optional Character Chart

	N.C. Pushbutton	Power Outage	Test Feature
A	X	X	X
B			X
C	X		
E		X	
F	X	X	
Y	X		X
Z		X	X
X	No Option		



Gems Sensors Inc.
One Cowles Road
Plainville, CT 06062-1198
Tel: 860-793-4579
Fax: 860-793-4580