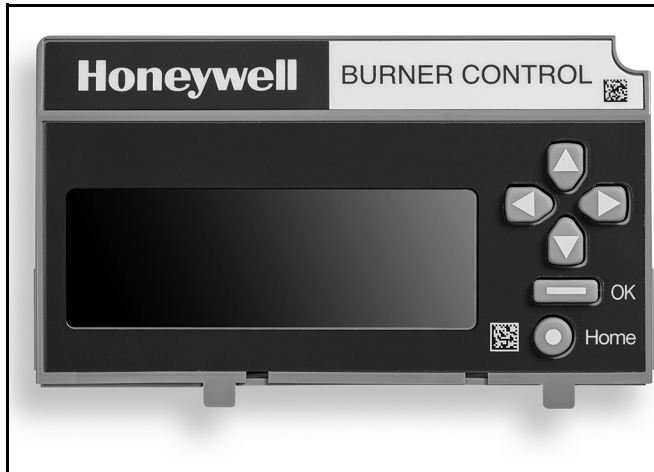


# Honeywell

# 7800 SERIES S7800A2142 Keyboard Display Module

## PRODUCT DATA



## APPLICATION

The S7800A2142 Keyboard Display Module (KDM) provides current system status along with first-out annunciation and system diagnosis using a five-row by 64-column readout. The KDM provides local or remote annunciation of operation and fault information, remote reset, report generation, burner control data and diagnostic information. The KDM is part of the 7800 SERIES of microprocessor-based burner controls for gas, oil, coal or combination fuel single burner applications.

The 7800 SERIES is programmed to provide a level of safety, functional capabilities and features beyond the capacity of conventional controls.

The S7800A2142 is required to program the Valve Proving feature of selected 7800 Series devices.

The S7800A2142 KDM offers the following technical advancements to the 7800 SERIES devices:

- Compatible with installed Honeywell 7800 SERIES systems.
- When used with the new 7800 SERIES with Valve Proving Feature, the KDM allows for programming the Valve Proving Control feature and timing (Pass Code protected feature).
- When used with the new 7800 SERIES with Postpurge feature, the KDM allows for programming the Postpurge time (Pass Code protected feature).
- Allows for naming the S7830 Expanded Annunciator terminals to match your system drawings. (Displayed message only.) (Pass Code protected feature.)
- An eight line by twenty column readout set of "Call Service" (Business Card) alpha/numeric directions can be displayed instead of the standard lockout display message. (Pass Code protected feature).
- Enable ModBus communication feature.
- Configure language for English, Spanish, or French.
- On-line troubleshooting guide.

The Business Card (Call Service) and Expanded Annunciator can be made up using:

- Capital letters (A through Z in configured language).
- Lower case letters (a through z in configured language).
- Numbers (0 through 9).
- Symbols (!, @, #, \$, %, etc.).

Programming can be done with the S7800 KDM mounted on a 7800 SERIES Relay Module or with a 13 Vdc power source connected to the KDM through the 203541 5-wire connector.

Since your Business Card (Call Service) S7800A2142 will be left at the job site, programming your personal three-number password and personal lockout message can be set up ahead of time without being connected to a 7800 SERIES device.

## Contents

Application .....	1
Features .....	2
Specifications .....	2
Installation .....	3
Wiring .....	5
Troubleshooting .....	11
Hold and Fault Message Summary .....	18

## Contents

Appendix A: Display Setup .....	28
Appendix B: Burner Control Commissioning .....	43
Appendix C: Diagnostics .....	49
Appendix D: Annunciator Terminal Messages .....	52
Appendix E: ModBus Function .....	54



32-00110-05

## FEATURES

- **Application flexibility.**
- **Communication interface capability.**
  - **Through Q7700 Network Interface Unit**
  - **Through 203541 Connector on the ModBus data highway.**
- **Dependable, long-term operation provided by microcomputer technology.**
- **First-out annunciation and system diagnostics provided by a 5-line by 64-character display.**
- **First-out expanded annunciation with 24 limit and interlock Light Emitting Diodes (LEDs).**
- **Local or remote annunciation of operation and fault information.**
- **UL NEMA Class 4 rating when p/n 204729A,C NEMA 4 cover is used.**
- **Remote reset.**
- **Report generation.**
- **On-line troubleshooting guide.**
- **Burner controller data:**
  - **Sequence status.**
  - **Sequence time.**
  - **Hold status.**
  - **Lockout/alarm status.**
  - **Flame signal strength.**
  - **Expanded annunciator status.**
  - **Total cycles of operation.**
  - **Total hours of operation.**
  - **Fault history of six most recent faults:**
    - Cycles of operation at time of fault.
    - Expanded annunciator data at time of fault.
    - Fault message and code.
    - Hours of operation at time of fault.
    - Sequence status at time of fault.
    - Sequence time at time of fault.
  - **Diagnostic information:**
    - Device type.
    - Flame amplifier type.
    - Flame failure response time (FFRT).
    - Manufacturing code.
    - On-Off status of all digital inputs and outputs.
    - Prepurge time
    - Postpurge time
    - Valve Proving mode
    - Valve Proving time
    - Software revision and version of 7800 SERIES.
    - Relay Module and KDM.
    - Status of configuration jumpers.
    - Status of Run/Test Switch.
    - Reset count
    - Reset reason

## SPECIFICATIONS

### Electrical Ratings:

Voltage and Frequency: 13 Vdc peak full wave rectified (+20%/-15%).

Power Dissipation: 7W maximum.

VA consumption: 2 VA maximum.

### Terminal Ratings:

Power: 13 Vdc peak full wave rectified.

Earth Ground.

### Environmental Ratings:

Ambient Temperature Ranges:

Operating: 0°F (-18°C) to +140°F (+60°C).

Storage: -22°F (-30°C) to +158°F (+70°C).

Humidity: 85% relative humidity continuous, noncondensing.

NOTE: UL NEMA Class 4 rating when P/N 204729A,C NEMA 4 Cover is used.

Vibration: 0.5G environment.

### Mechanical:

Dimensions: See Fig. 1.

Weight: 4 oz. (124 grams), unpacked.

### Display:

5 lines by 64 characters with title and navigation bar.

### Languages:

S7800A2142 English/Spanish/French Language display.

### Approvals:

Underwriters Laboratories Inc. Listed: File No. MP268, guide No. MCCZ.

Factory Mutual Approved: Report No. J.I.1V9AO.AF.

IRI: Acceptable.

Federal Communications Commission: Part 15, Class B emissions.

EN60730: For compliance with remote KDM mounting requirements, provide electrical insulation separation by insulation using double or reinforced insulation. Do this by: Optically isolating the communication or remote reset lines from the control cabinet, or provide physical separation from the communication or remote display cover assembly (part number 204729A) or other suitable enclosure that meets the IP40 class of protection.

### Accessories:

203541 ControlBus™ 5-wire Electrical Connector.

S7810A1009 Data ControlBus™ Module.

203765 Remote Display Mounting Bracket.

221818A 60 in. (1.5 m) Extension Cable Assembly.

221818C 120 in. (3 m) Extension Cable Assembly.

204729A NEMA 4 Cover Assembly for S7800A KDM.

204729C NEMA 4 Cover Assembly for S7800A KDM with reset button.

205321B Remote Display Flush Mount Kit.

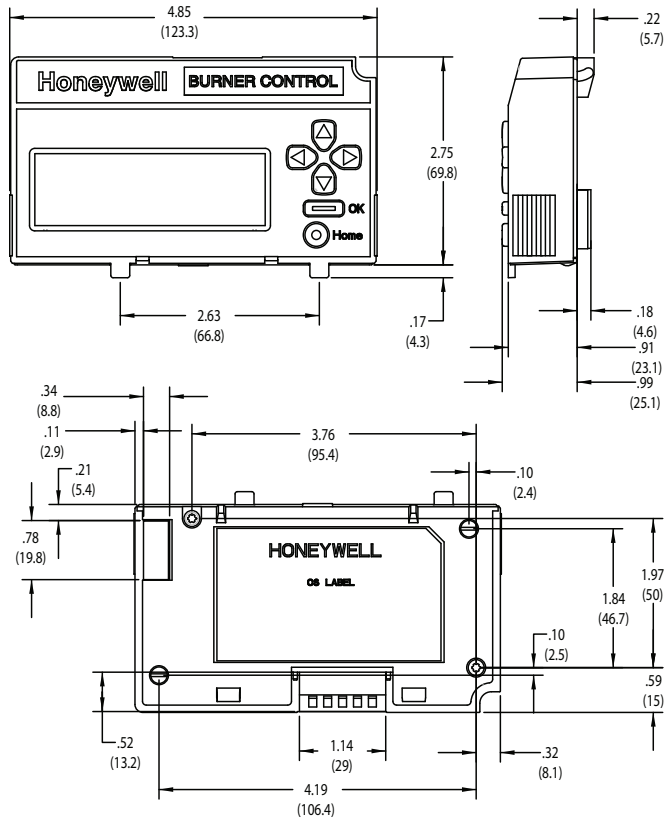


Fig. 1. Approximate dimensions of S7800A2142 in. (mm).

## INSTALLATION



### WARNING

**Electrical Shock Hazard.**  
Can cause severe injury, death or property damage.

Disconnect the power supply before beginning installation to prevent electrical shock and equipment damage. More than one power supply disconnect can be involved.

### When Installing This Product...

1. Read these instructions carefully. Failure to follow them could damage the product or cause a hazardous condition.
2. Check the ratings given in the instructions and marked on the product to make sure the product is suitable for your application.
3. Installer must be a trained, experienced, flame safeguard service technician.
4. After installation is complete, check out the product operation as provided in these instructions.
5. Be sure wiring complies with all applicable codes, ordinances and regulations.
6. See Fig. 3 for S7800A unique wiring connections.

### IMPORTANT

1. This equipment generates, uses and can radiate radio frequency energy and, if not installed and used in accordance with the instructions, can cause interference to radio communications. It has been tested and found to comply with the limits for a Class B computing device of Part 15 of FCC rules which are designed to provide reasonable protection against such interference when operated in a commercial environment. Operation of this equipment in a residential area can cause interference, in which case, users, at their own expense, can be required to take whatever measures are required to correct this interference.
2. This digital apparatus does not exceed the Class B limits for radio noise for digital apparatus set out in the Radio Interference Regulations of the Canadian Department of Communications.

### Humidity

Install the S7800A where the relative humidity never reaches the saturation point. The S7800 is designed to operate in a maximum 85% RH continuous, noncondensing, moisture environment.

### Vibration

Do not install the S7800A where it can be subjected to vibration in excess of 0.5G continuous maximum vibration.

### Temperature

Temperatures below 20°F (-7°C) may cause a slow screen refresh rate and ghosting. This effect will be most evident during cold start-up (display has not been operating and is in a <20°F [-7°C] environment). This is due to the time required for the display to warm up. If the display does not fully recover within 5 minutes, then check the systems line input voltage to insure it is within specifications.

### Weather

The S7800A is not designed to be weather tight. If installed outdoors, the S7800A must be protected by an approved weather-tight enclosure such as the 204729A or 204729C NEMA 4 Enclosure listed in Accessories.

### S7800A2142 Embedded Features

- A. See Appendix A to set up the following features:
- Call Service (Business Card) information displayed when burner system is in Lockout of the 7800 SERIES device.
  - Customizing of Expanded Annunciator (S7830) message to match a given installed limit string. If ModBus Feature is required, use S7810M1003 ModBus Module.
  - ModBus communication setup and enable feature: Note that this will occupy terminals 1, 2, 3 of the 203541 Connector on the KDM, which disables the Expanded Annunciator Features.

**SERVICE NOTE:**

The S7800A2142 can either do the Expanded Annunciator Feature or ModBus -- not both. If BOTH are required, order the S7810M1003 ModBus Module for the ModBus option.

B. The S7800A2142 KDM is also used to program the Valve Proving and Post-purge feature of Select RM7800 SERIES devices. See Appendix B.

## Mounting KDM on 7800 SERIES Relay Module.

1. Align the two interlocking ears of the KDM with the two mating slots on the 7800 SERIES Relay Module. See Fig. 2.



**Fig. 2. Keyboard Display Module mounting.**

2. Insert the two interlocking ears into the two mating slots and, with a hinge action, push on the lower corners of the KDM to secure it to the 7800 SERIES Relay Module.
3. Make sure the KDM is firmly in place.

## Remote Mounting KDM

The KDM can be mounted either on the face of a panel door or on other remote locations. When mounting the KDM on the face of a door panel, closely follow these instructions:

1. Select the location on the door panel for flush mounting.
2. Pay attention to the insertion dimensions of the two KDM screws, two interlocking ears, and the two plug-in connections to allow for sufficient clearance.
3. Use the KDM or Data ControlBus Module™ as a template (Fig. 28) and mark the two screw locations, interlocking ear locations and the two plug-in connector locations.
4. Drill the pilot holes for the mounting screws.
5. Cut holes in the door panel for the interlocking ears and the two plug-in connectors.
6. Mount the KDM, securing it with the two screws provided in the KDM bag assembly.

## Remote Display Mounting Bracket

Use the 203765 Remote Display Mounting Bracket when mounting the KDM on a wall or remote location:

1. Use the 203765 Remote Display Mounting Bracket as a template to mark the four screw locations.
2. Drill the pilot holes for the four mounting screws.
3. Mount the 203765 Remote Display Mounting Bracket by securing the four no. 6 screws (M3.5 x 0.6).
4. Mount the KDM by aligning the two interlocking ears with the two mating slots on the remote mounting bracket.
5. Insert the two interlocking ears into the two mating slots.
6. Push on the lower corners of the KDM to secure it to the remote mounting bracket.
7. Make sure the KDM is firmly in place.

## WIRING



### WARNING

**Electrical Shock Hazard.**

**Can cause severe injury or death.**

To prevent electrical shock and equipment damage, disconnect the power supply from the main disconnect before beginning installation. More than one disconnect can be involved.

1. Refer to Fig. 3 for proper wiring.
2. Make sure all wiring complies with all applicable electrical codes, ordinances and regulations.
3. For recommended wire size and type, see Table 1.
4. For Recommended grounding practices, see Table 2.
5. For KDM: The KDM is powered from a low voltage, energy-limited source. It can be mounted outside of a control panel if it is protected from mechanical damage.

NOTE: A 13 Vdc power supply must be used any time more than one KDM is used. A maximum of two KDM, Data ControlBus™ Modules or S7810B Multi-Drop Switch Modules are allowed in any combination.

**Table 1. Recommended Wire Size and Part Number.**

Application	Recommended Wire Size	Recommended Part Number
Keyboard Display Module	22 AWG two-wire twisted pair with ground, or five-wire.	Belden 8723 shielded cable or equivalent.
Data ControlBus™ Module	22 AWG two-wire twisted pair with ground, or five-wire.	Belden 8723 shielded cable or equivalent.
Remote Reset Module	22 AWG two-wire twisted pair, insulated for low voltage.	—
Communications Interface ControlBus Module™	22 AWG two-wire twisted pair with ground.	Belden 8723 shielded cable or equivalent.
13 Vdc full wave rectified transformer power input.	18 AWG wire, insulated for voltages and temperatures for given applications.	TTW60C, THW75C, THHN90C

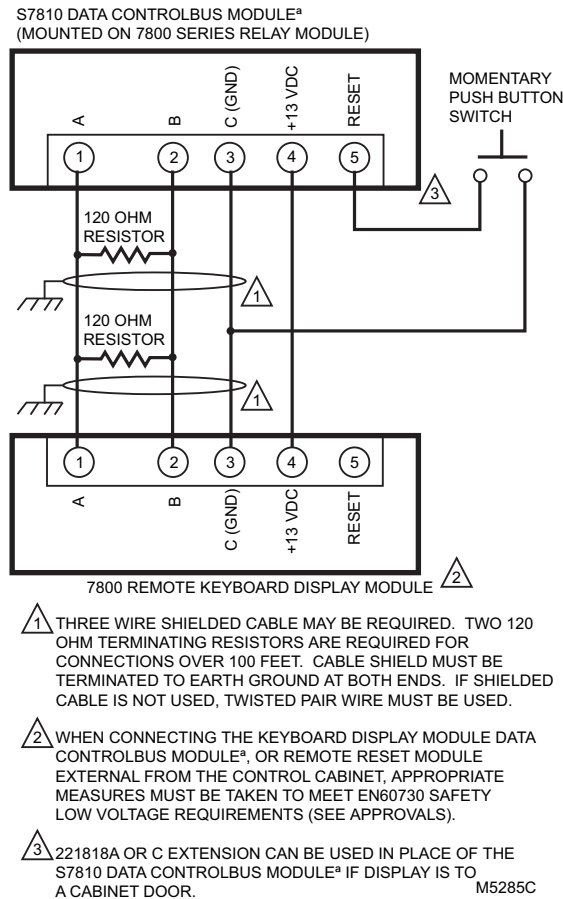
**Table 2. Recommended Grounding Practices.**

Ground Type	Recommended Practice
Signal ground (KDM, Data ControlBus™ Module, Communications Interface ControlBus Module™).	Use the shield of the signal wire to ground the device to the signal ground terminals [3(c)] of each device. Connect the shield at both ends of the daisy chain to ground.

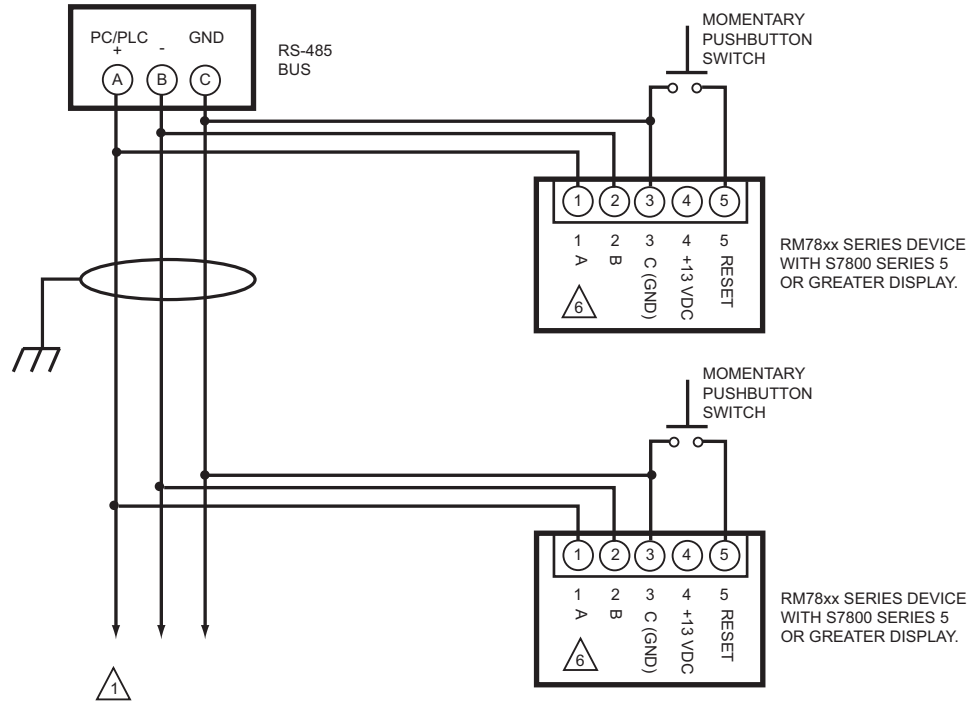
6. Recommended wire routing:
  - a. ControlBus:
    - (1) Do not route the ControlBus cable in conduits that carry line voltage circuits.
    - (2) Avoid routing the ControlBus cable close to ignition transformer leadwires.
    - (3) Route the ControlBus cable outside of conduit if properly supported and protected from damage.
  - b. Remote Reset:
    - (1) Do not run high voltage ignition transformer wires in the same conduit with the Remote Reset wiring.
    - (2) Do not route Remote Reset wires in conduit with line voltage circuits.
7. Maximum wire lengths:
  - a. KDM: The maximum length interconnecting wire is 4000 ft (1219m).
  - b. Remote Reset leadwires: The maximum length wire is 1000 ft (300m) to a Remote Reset push-button.
8. Install all electrical connectors.
9. Restore power to the panel.

## KDM Display

The first line of the KDM display provides current status of the burner sequence (STANDBY, PURGE, PILOT IGN, MAIN IGN, RUN and POSTPURGE), timing information (PURGE, PILOT IGN, MAIN IGN and POSTPURGE) in minutes and seconds, hold information (PURGE HOLD), and lockout information (Lockout, Fault Code, Message and Sequence). The second line will display selectable or preemptive messages. A selectable message supplies information for flame strength, system status indication, system or self-diagnostics and troubleshooting. A preemptive message has parentheses around the message and supplies a detailed message to support the sequence status information. A preemptive message can also be a lockout message. A preemptive message replaces a selectable message to support the sequence status information. The 7800 SERIES Relay Module LED provide positive visual indication of the Relay Module sequence. The LED is energized simultaneously with the correct sequence description.



**Fig. 3. Wiring Keyboard Display Module for remote mounting.**



- 1 MULTI-DROP RS-485 COMMUNICATION BUS. UP TO 31 S7800 SERIES 5 OR GREATER DISPLAYS CAN BE CONNECTED TO A SINGLE BUS WITHOUT AN RS-485 REPEATER. UP TO 99 MODBUS™ (SUBNETWORKS) CAN BE CONNECTED TO A BUS WITH RS-485 REPEATERS. WHEN USING AN RS-485 REPEATER, THE REPEATER MUST BE INSTALLED EVERY 30TH MODULE.
- 2 THE SUBNETWORKS MUST BE WIRED IN A DAISY CHAIN CONFIGURATION. RECOMMEND THAT THE PC/PLC BE AT ONE END OF THE DAISY CHAIN.
- 3 MODBUS™ COMMUNICATION BUS TERMINATION RESISTORS:
  - A. WITHOUT RS-485 REPEATER:  
 MODULES AT THE CLOSEST AND FARTHEST END OF THE DAISY CHAIN REQUIRE TERMINATION RESISTORS. INSTALL A 120 OHM, 1/4 WATT RESISTOR BETWEEN TERMINALS A AND B OF THE PC/PLC (IF INSTALLED AT ONE END THE DAISY CHAIN). INSTALL A 120 OHM, 1/4 WATT RESISTOR BETWEEN TERMINALS 7 AND 8 OF THE LAST S7810M MODBUS™ MODULE IN THE DAISY CHAIN.
  - B. WITH RS-485 REPEATER:  
 WHEN AN RS-485 REATER IS USED, TWO DAISY CHAIN CONFIGURATIONS ARE EFFECTIVELY FORMED. MODULES AT THE CLOSEST AND FARTHEST ENDS OF EACH DAISY CHAIN REQUIRE TERMINATION RESISTORS. INSTALL A 120 OHM, 1/4 WATT RESISTOR BETWEEN TERMINALS A AND B OF THE PC/PLC (IF INSTALLED AT THE END OF THE DAISY CHAIN). INSTALL A 120 OHM, 1/4 WATT RESISTOR BETWEEN INPUT TERMINALS DATA+ AND DATA- OF THE RS-485 REPEATER. INSTALL A 120 OHM, 1/4 WATT RESISTOR BETWEEN TERMINALS 7 AND 8 OF THE LAST S7810M MODBUS™ MODULE IN THE ADDITIONAL DAISY CHAIN.
- 4 LOCAL RS-485 COMMUNICATIONS BUS. THE DEVICES ON THIS BUS MUST BE WIRED IN A DAISY CHAIN CONFIGURATION. THE ORDER OF INTERCONNECTION IS NOT IMPORTANT. THE MODULES ON THE CLOSEST AND FARTHEST ENDS OF THE DAISY CHAIN REQUIRE A 120 OHM, 1/4 WATT TERMINATION RESISTOR BETWEEN TERMINALS 1 AND 2 OR A AND B.
- 5 THREE WIRE SHIELDED CABLE (BELDEN 8723 SHIELDED OR EQUIVALENT) IS RECOMMENDED AND SHOULD BE GROUNDED AS FOLLOWS: IF NO INTERFERENCE IS PRESENT, OR TO REDUCE CAPACITIVE INTERFERENCE, THE SHIELD SHOULD BE GROUNDED AT ONE END. WHEN GROUNDING ONLY ONE END OF THE THE SHIELD, THE SHIELD END CLOSEST TO THE S7810M MODBUS™ MODULE SHOULD BE ATTACHED TO EARTH GROUND. TO REDUCE INDUCTIVE INTERFERENCE (RF INTERFERENCE), THE SHIELD SHOULD BE GROUNDED AT BOTH ENDS.
- 6 TERMINAL NUMBERS ARE ON 203541 5-WIRE CONNECTOR (SUPPLIED WITH REMOTE MOUNTING BRACKET).

M24190

**Fig. 4. Wiring for ModBus™ Feature.**

NOTE: LED has been replaced by block characters visible on the MB address setup menu.



Fig. 5. S7800 Keyboard Display Module.

## Keyboard Functions

The keyboard contains six push-buttons that are used to navigate on each page and between pages on the display module (see Fig. 6). These buttons generally have the following functions:

- **Up arrow** - move up on a page or increment a value for an input control
- **Down arrow** - move down on a page or decrement a value for an input control
- **Left arrow** - move to the left on a page (tab left) or go to a previous page
- **Right arrow** - move to the right on a page (tab right) or go to the next page when applicable
- **OK** - approve/accept the highlighted item or go to the next page when applicable
- **Home** - go to the Home (Main Status) page

These buttons are acted on when they are pressed and released. In some cases a button can be pressed and held, i.e., not released, for repeated execution of the button (arrow buttons). Buttons are active on some pages only when the action for the button makes sense for the position of the input focus on the page. If the input focus doesn't make sense for the button action, selecting the button is ignored.

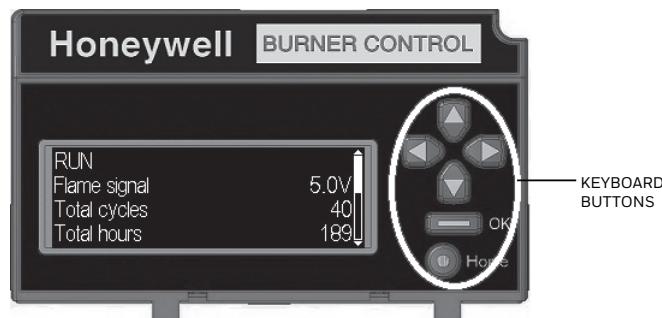


Fig. 6. Keyboard buttons.

When the burner control module is in a Lockout condition the "Home" button navigates to the Lockout page instead of the Home page to display the lockout.

## Page Structure

The Home and Lockout pages display text using a larger font size than all other pages so that information on them can be more easily viewed from distances farther away from the display module (see Fig. 7 and Fig. 8).

Up to 4 lines of text are displayed at a time on the page. When the page has more than 4 lines of text to display a scroll bar is present on the right-hand side of the page to indicate this situation. The "Up arrow" and "Down arrow" buttons are used to scroll up and down the lines of the page. Each line is highlighted with a white background to indicate that it currently has input focus for any button actions. The scroll bar adjusts to give a relative position of the current view with respect to all lines that the page can display.

When a line has a right arrow symbol positioned on the righthand side it indicates that this line can navigate to another page, "Next page", related to the subject of the line when that line has input focus. A "Right arrow" or "OK" button can be pressed when the focus is on this line to navigate to the next page.

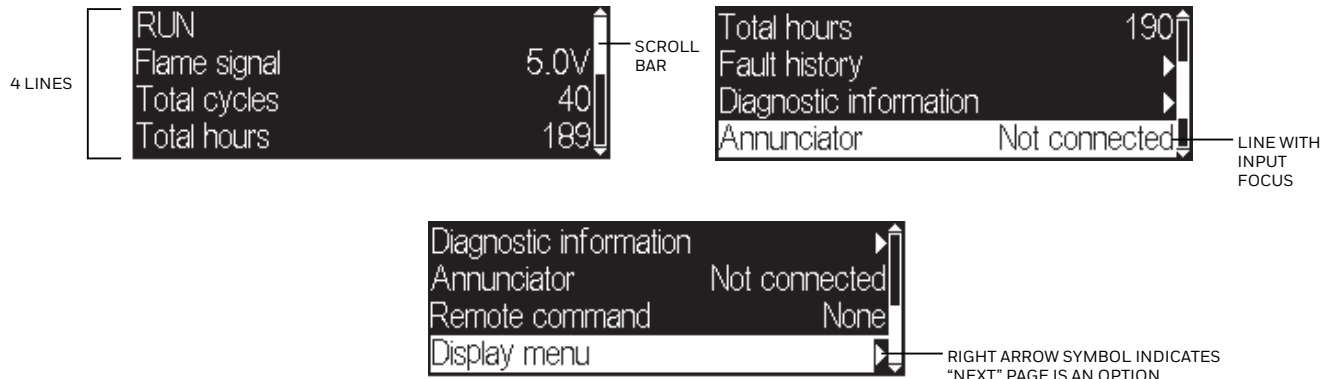


Fig. 7. Home page

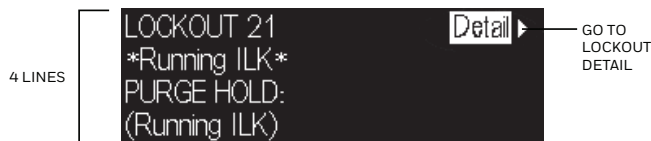


Fig. 8. Lockout page

For pages other than Home and Lockout a smaller font size is used to display the text and pages have a format like the one shown in Fig. 9.



Fig. 9. Page structure

The top line of the page is a title that describes the context or purpose of the page (see Fig. 9).The bottom line of the page is a navigation bar which indicates the more important button actions that can be performed for the current input focus (see Fig. 10). The middle or main body of the page contains the lines that show information or allow for user input. Up to 5 lines of text may be displayed in the main body. Solid lines separate the title and navigation bar from the main body.

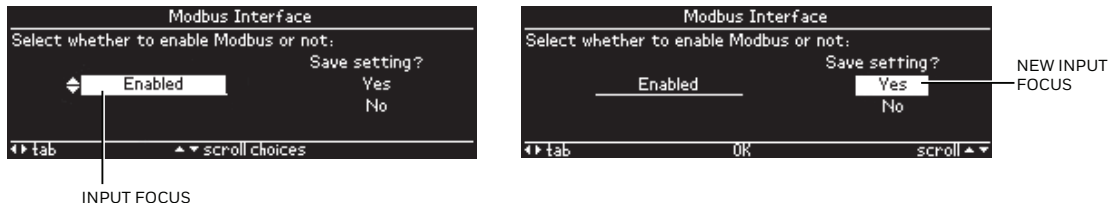


Fig. 10. Input focus

An item on a page that has input focus is usually highlighted with an inverse look (black text on white background) to distinguish it from the rest of the page. The arrow buttons move the input focus to another selectable item if another one exists on the page (some pages may only have a single focus item).

For pages that allow user input (see Fig. 10) the input value is edited on the page and then is acknowledged or confirmed at another tab position on the page ("Yes" tab in the above example). This confirmation action permits the user to cancel the editing and not commit to the change or to accept the edited value.

## Home Page

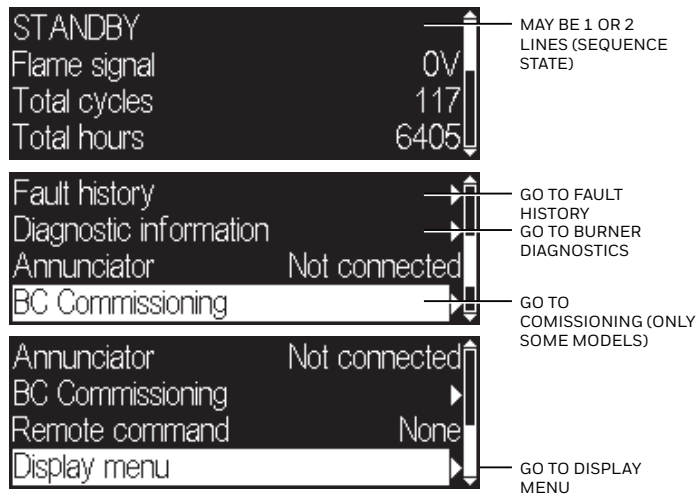
The Home page is the main status page that displays primary status of the burner control operation (see Fig. 11). This page is intended to be the primary one displayed most often when the user is not specifically looking for other information or configuring the display. The following information is displayed by default:

- Burner control sequence or lockout state
- Flame signal strength
- Total cycles count
- Total run-time hours count
- Annunciator connection status
- Remote command status

The burner control sequence state may be displayed in one or two lines due to the length of the text. In case of two lines the remaining lines are pushed down to make room for the second line.

This page also permits navigation to the following pages:

- Lockout message (when burner control is in a lockout condition)
- Fault history
- Burner control diagnostic status
- Annunciator diagnostic status (when annunciator is connected)
- Burner control commissioning (supported models only)
- Display menu



**Fig. 11. Home page status**

An additional status line can be displayed between the burner control sequence line(s) and the flame signal strength line when configured (see "Selected Status Message" on page 37). Fig. 12 shows an example with the T6 terminal ("Demand") status displayed.



**Fig. 12. Home page selected status**

The lines are scrollable using the up and down arrows. For lines that navigate to another page the right arrow or OK button is pressed when the line has input focus (highlighted) to go to the new page.

## TROUBLESHOOTING

After the KDM is installed, return the 7800 SERIES to normal operation, restore power and run the system through at least one complete automatic cycle. For complete Troubleshooting and System Checkout information, see form 65-0229.

### 7800 SERIES System Diagnostics

Troubleshooting control system equipment failures is made easier with the 7800 SERIES self-diagnostics and first-out annunciation. The S7800 provides visual annunciation by displaying a fault code and fault or hold message on the display.

Self-diagnostics of the 7800 SERIES enables it to detect and annunciate both external and internal system problems. Internal faults and external faults such as interlock failures, flame failures and false flame signals are annunciated by the KDM via the 7800 SERIES Relay Module.

The KDM displays a sequence status message indicating STANDBY, PREPURGE, PRE-IGNITION, SAFETY 1, PILOT IGN, PILOT STAB., MAIN IGN, RUN or POSTPURGE, as appropriate. The selectable messages also provide visual indication of current status and historical status of the equipment, such as: Flame Signal, Total Cycles, Total Hours, Fault History, Diagnostic Information and Expanded Annunciator terminal status (if used). With this information, most problems can be diagnosed without extensive trial-and-error testing.

Table 3 provides the sequence and status hold messages. These messages along with the fault messages (Table 5) can be viewed on-line in the KDM.

**Table 3. Keyboard Display Module Sequence and Status Hold Messages .**

<b>Sequence</b>	<b>Status</b>
INITIATE mm:ss	The Keyboard Display Module (KDM) indicates the burner status, INITIATE, a stabilization period for the relay module to check for any fluctuations in ac line voltage inputs or control inputs on power up or during normal operation. The timing of the INITIATE period is either two seconds or ten seconds, depending on the model, before entering STANDBY.
If the relay module is in an INITIATE HOLD status, the following conditions could exist:	
INITIATE HOLD: (AC Frequency/Noise)	The KDM indicates the burner status and that it is waiting for excess line noise to clear up, which prevents sufficient reading of the line voltage inputs. The burner sequence does not advance into STANDBY until the excess line noise ceases or a line frequency error occurs; this is caused by using a 60 Hz device on a 50 Hz line, or vice versa on devices with a date code earlier than 9804, is corrected.
INITIATE HOLD: (AC Line Dropout)	The KDM indicates the burner status and that ac line power has momentarily dropped out. The burner sequence does not advance into STANDBY until the ac line voltage has stabilized throughout the INITIATE sequence.
INITIATE HOLD: (AC Frequency)	The KDM indicates the burner status and that line frequency is faster than the expected value. The burner sequence does not advance into STANDBY until the line frequency returns to the proper value; this is perhaps caused by using a 60 Hz device on a 50 Hz line for devices with a date code earlier than 9804.
INITIATE HOLD: (Low Line Voltage)	The KDM indicates the burner status and that low line voltage (10% lower than rated voltage) has occurred. The burner sequence does not advance into STANDBY until the line voltage is at a sufficient level for proper operating parameters.
STANDBY	The KDM indicates the burner status, STANDBY. The burner can be placed in STANDBY by opening the burner switch or if the operating controller indicates its setpoint is satisfied. If a demand is present for burner operation, the burner sequence does not advance from STANDBY to PURGE until the recycle limits close. If an Expanded Annunciator is connected, the display messages are enhanced.
If the relay module is in a STANDBY HOLD status, the following conditions could exist:	
STANDBY HOLD: F/G (Flame Detected)	The KDM indicates the burner status and that a flame is detected. A demand is present for burner operation. The sequence does not advance to PREPURGE until the flame signal clears. If the flame signal does not clear within 40 seconds, the relay module locks out.
STANDBY HOLD: T20 (Pre-Ignition Interlock)	The KDM indicates the burner status and that the Pre-Ignition Interlock is not closed. A demand is present for burner operation, but the burner sequence does not advance to PREPURGE until the Pre-Ignition Interlock proves closed. If this time exceeds a 30 second hold, the relay module locks out.

**Table 3. Keyboard Display Module Sequence and Status Hold Messages (Continued).**

<b>Sequence</b>	<b>Status</b>
STANDBY HOLD: T7 (Lockout Interlock)	The KDM indicates the burner status and that the Lockout Interlock is closed. A demand is present for burner operation, but the burner sequence does not advance to PREPURGE until the Lockout Interlock proves open. If this time exceeds the 120 second hold, the relay module locks out.
STANDBY HOLD: T7 (Running Interlock) EC/RM7850	The KDM indicates the burner status and that the Running Interlock is closed. A demand is present for burner operation, but the burner sequence does not advance to PREPURGE until the Running Interlock proves open. If this time exceeds the 120 second hold, the relay module locks out.
PURGE	The KDM indicates the burner status, PURGE, which is the period of time the blower motor is running before the Ignition period. The timing of the PURGE period is selectable.
If the relay module is in a PURGE HOLD status, the following conditions could exist:	
PURGE HOLD: T19 (High Fire Switch)	The KDM indicates the burner status and that the High Fire Switch is not closed. The firing rate motor is driving to its PURGE rate position. If this time exceeds four minutes and fifteen seconds, the relay module locks out.
PURGE DELAY: T19 (High Fire Switch Jumpered)	The KDM indicates the burner status and that the High Fire Switch is jumpered. The High Fire Switch is bypassed, welded or otherwise prematurely closed. The system automatically adds 30 seconds to allow the firing rate motor additional drive time to reach or near the open damper position before starting the PURGE sequence.
PURGE HOLD: TEST (Run/Test Switch)	The KDM indicates the burner status and that the Run/Test Switch is in the TEST position. The sequence does not continue until the Run/Test Switch is placed in the RUN position.
PURGE HOLD: T18 (Low Fire Switch Jumpered)	The KDM indicates the burner status and that the Low Fire Switch is jumpered. The Low Fire Switch is bypassed, welded or otherwise prematurely closed. The system automatically adds 30 seconds to allow the firing rate motor additional drive time to reach or near the closed damper position before starting the ignition sequence.
PURGE HOLD: F/G (Flame Detected)	The KDM indicates the burner status and that a flame is detected. The burner sequence does not advance through PREPURGE because a flame is detected as being present. The sequence holds waiting for the flame signal to clear. If the time exceeds 30 seconds, the relay module locks out.
PURGE HOLD: T18 (Low Fire Switch)	The KDM indicates the burner status and that the Low Fire Switch is not closed. The firing rate motor is driving to its Low Fire position in preparation for Ignition Trials. If this time exceeds four minutes and fifteen seconds, the relay module locks out.
PURGE HOLD: T7 (Running Interlock)	The KDM indicates the burner status and that the Running Interlock is not closed. The sequence does not advance to ignition until the Running Interlock proves closed. If this time exceeds 30 seconds, the relay module locks out.
PILOT IGN mm:ss	The KDM indicates the burner status, PILOT IGN, and the timing of the PILOT IGN trial begins, in seconds. During this period, the relay module permits the pilot valve to open and the pilot flame to establish.
If the relay module is in a PILOT HOLD status, the following conditions could exist:	
PILOT HOLD: TEST (Run/Test Switch)	The KDM indicates the burner status, PILOT IGN, and that the Run/Test Switch is in the TEST position. The sequence does not continue until the Run/Test Switch is placed in the RUN position.
MAIN IGN mm:ss	The KDM indicates the burner status, MAIN IGN, and the timing of the MAIN IGN trial begins, in seconds. During this period, the relay module permits the main valve to open and the main flame to establish.
RUN	The KDM indicates the burner status, RUN, which is the period of time after the Ignition Trials and before the operating controller setpoint is reached. During this time, the burner is firing under control of the firing rate control.
If the relay module is in a RUN HOLD status, the following condition could exist:	
RUN LOWFIRE: TEST (Run/Test Switch)	The KDM indicates the burner status and that the Run/Test Switch is in the TEST position. Normal modulation or operation does not continue until the Run/Test Switch is placed in the RUN position.
POSTPURGE mm:ss	The KDM indicates the burner status, POSTPURGE, which is the period of time after the RUN period when the blower motor continues to run. The timing of the POSTPURGE period is fifteen seconds.
Waiting for connection...	The KDM has power but is waiting to receive a signal from the relay module to continue operation.

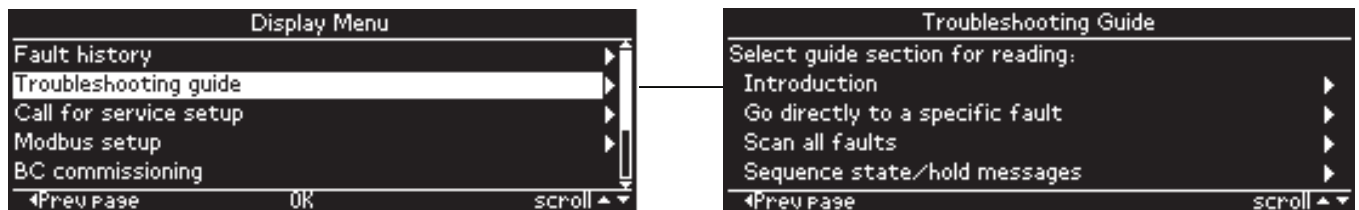
**Table 3. Keyboard Display Module Sequence and Status Hold Messages (Continued).**

Sequence	Status
RESET/ALARM TEST	The KDM indicates the burner status, RESET/ALARM TEST. This condition indicates that the reset button is pressed. If it is held for more than four seconds, the alarm output is energized. The alarm output is de-energized when the reset button is released.
Additional Sequence Status Information When An Expanded Annunciator is Connected to the Relay Module:	
BURNER OFF: T6 (Burner Switch)	The KDM indicates the Burner Switch is not closed. The burner sequence does not advance to PREPURGE until the Burner Switch closes.
STANDBY	The KDM indicates the burner status, STANDBY, and that the Operating Control is not closed. The burner sequence does not advance to PREPURGE until the Operating Control closes.
STANDBY HOLD: T6 (EA Hold Message)	The KDM indicates the burner status, STANDBY, and that a limit is not closed. The burner sequence does not advance to PREPURGE until one or all limits close downstream from the Operating Control.
STANDBY HOLD: T6 (Circuit Fault)	The KDM indicates the burner status, STANDBY, and that the control input is not closed. The burner sequence does not advance to PREPURGE until the control input closes.

The S7800 provides diagnostic information to aid the service mechanic in obtaining information when troubleshooting the system. See Table 4 for information on accessing historical and diagnostic selectable messages. Information available in the Diagnostic Information includes Device Type, Software Revision, Manufacturing Code, Flame Amplifier Type, Flame Failure Response Time (FFRT), Selectable Jumper Configuration Status, Run/Test Switch Status and Terminal Status.

Information from the above table and Table 5 are viewable in the display module. The troubleshooting guide can be accessed from the Display Menu (see Fig. 13). A menu is displayed that permits access to these different sections of the guide:

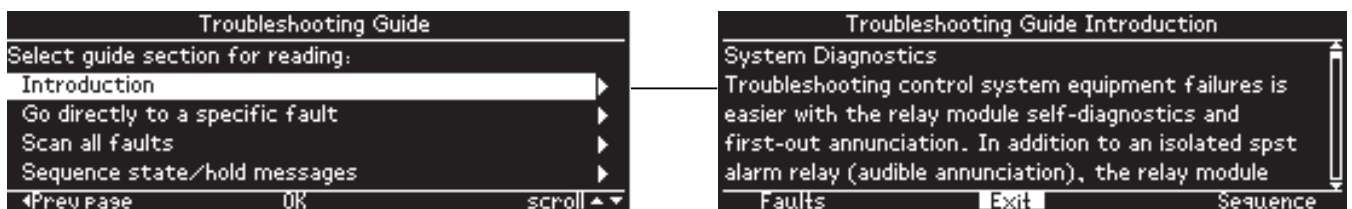
- Introduction
- Faults
- Sequence and Status Hold messages

**Fig. 13. Troubleshooting guide menu**

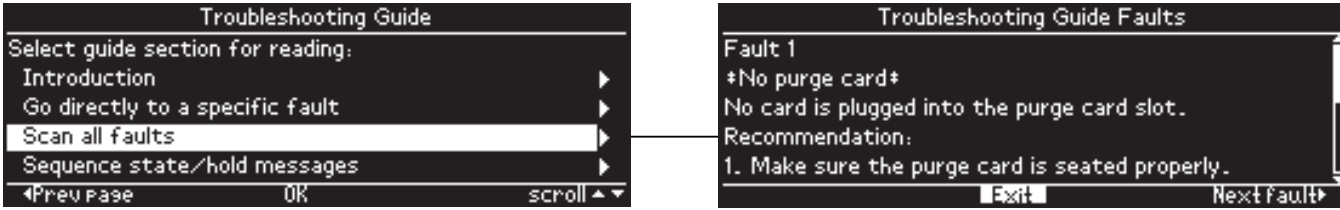
The Introduction section contains brief troubleshooting tips and is presented in a scrollable paragraph form for reading using the up and down arrow buttons (see Fig. 14). The navigation bar contains the following commands that can be selected using the right and left arrow buttons:

- “Faults” – go to Troubleshooting guide Faults section
- “Exit” – exit Introduction section and return back to Troubleshooting guide menu
- “Sequence” – go to Troubleshooting guide Sequence/Status Hold section

Pressing the OK button executes the command with the current input focus.

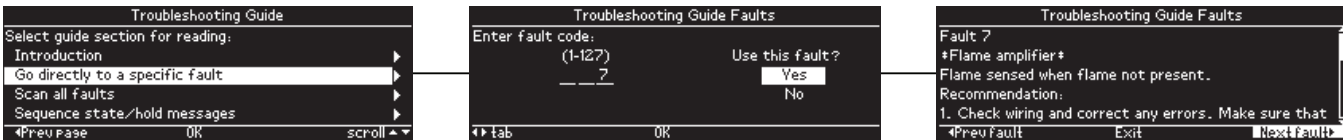
**Fig. 14. Troubleshooting guide introduction**

The Faults section presents a description and recommended actions for each fault that the burner control module may have (see Fig. 15). The information is presented for a single fault code and when more lines are needed to display the information than can fit on the page, the up and down arrow buttons are used to scroll through the lines.



**Fig. 15. Troubleshooting guide faults section**

The Faults section can be accessed starting at the beginning (see Fig. 15) or by going directly to a specific fault code (see Fig. 16).



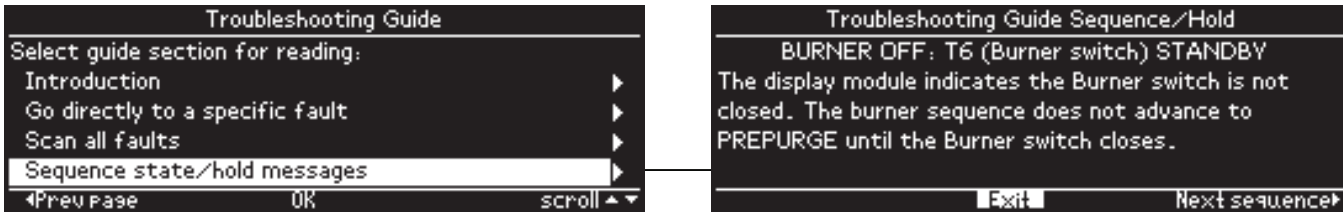
**Fig. 16. Troubleshooting guide direct fault access**

The Faults navigation bar contains the following commands that can be selected using the right and left arrow buttons:

- “Prev fault” – go to previous fault code
- “Exit” – exit Faults section and return back to Troubleshooting guide menu
- “Next fault” – go to next fault code

Pressing the OK button executes the command with the current input focus.

The Sequence and Status Hold section explains the meaning of different sequence state and status hold messages that can display for a burner control on the display module (see Fig. 17). The up and down arrow buttons are used to scroll the lines of the explanation.

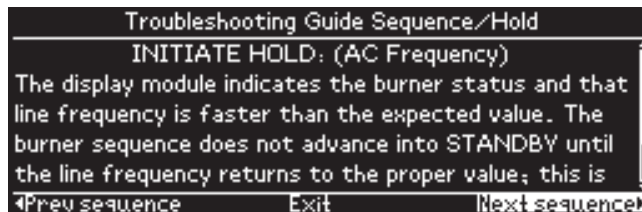


**Fig. 17. Troubleshooting guide sequence section**

The Sequence/Status Hold navigation bar (see Fig. 18) contains the following commands that can be selected using the right and left arrow buttons:

- “Prev sequence” – go to previous sequence/status hold message
- “Exit” – exit Sequence/Status Hold section and return back to Troubleshooting guide menu
- “Next sequence” – go to next sequence/status hold message

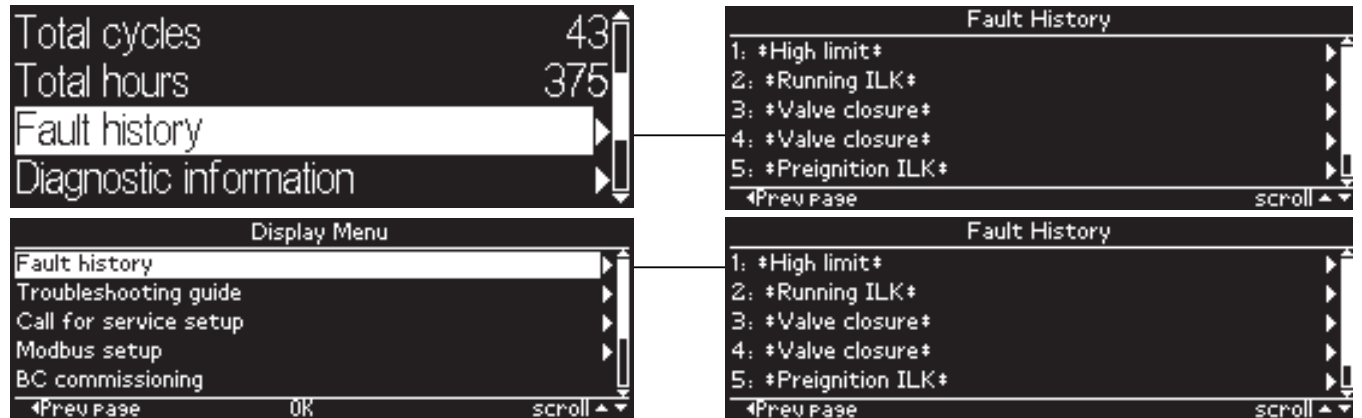
Pressing the OK button executes the command with the current input focus.



**Fig. 18. Troubleshooting guide sequence section (continued)**

## Historical Information Index

The S7800 displays historical information for the six most recent lockouts. Each of the six lockout records retains the cycle when the fault occurred, a fault code, a fault message, and burner status when the fault occurred. The fault history can be accessed from either the Home or Display Menu pages (see Fig. 19).



**Fig. 19. Fault history menu**

The fault history is displayed in order from most recent lockout, #1, on the first line to the oldest lockout on the last line. The up and down arrow buttons are used to scroll to the lockout desired and the right arrow or OK button is pressed to view the fault information (see Fig. 20) for that lockout.

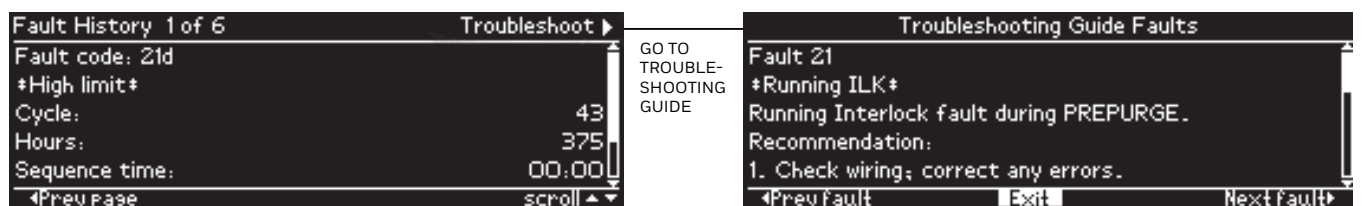


**Fig. 20. Fault history record**

The fault record is scrollable using the up and down arrow buttons to see all lines of the information. The fault description can take 1 or 2 lines to display and is presented on the line(s) below the fault code line. Below the sequence time line is displayed the sequence state that the burner control was in at the time of the fault. This state description may take 1 or 2 lines to display also.

The left arrow button can be pressed to exit this fault record and go back to the Fault history menu (previous page).

The title bar displays which fault history record is displayed and indicates that the Troubleshooting guide can be navigated to using the “Next page” (right arrow) button (see Fig. 21).



**Fig. 21. Troubleshooting guide from fault history record**

When the “Exit” command in the troubleshooting guide has input focus and the OK button is pressed control returns back to the fault history record.

**Table 4. Accessing Historical and Diagnostic Selectable Messages.**

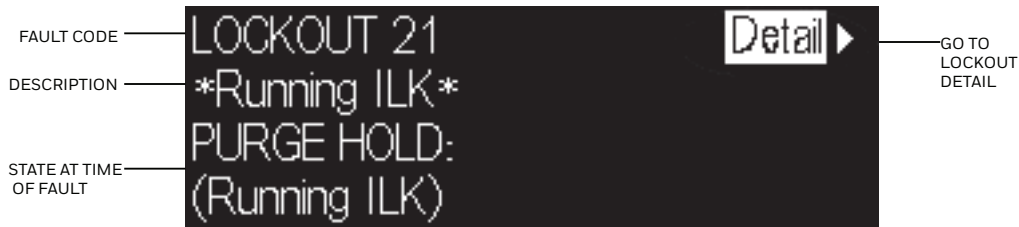
Step	Operation	Press	Display	Comments
1.	Press ↑↓ buttons to access Diagnostic Information.	↑↓	STANDBY Diagnostic Information>	Use the Down/Up arrow buttons to access the "Diagnostic information" line.
2.	Press ► button to access Diagnostic Information.	◀ ►	STANDBY Diagnostic Information>	Use the right arrow or OK button to access the Diagnostic Information.
3.	Continue display of Diagnostic Information.	↑↓	Device RM7800<	Push the Down/Up arrow buttons to scroll through the burner control diagnostic status.
4.	Continue through remaining diagnostic information display following step 3 as required.	—	—	—
5.	Press the ◀ arrow button to return to the Home page	◀ ►	STANDBY Diagnostic Information>	Another display can be selected or discontinue accessing Diagnostic Information review.

**SERVICE NOTE:** If the Keyboard Display Module screen is scrambled, remove and reinstall the Keyboard Display Module and reset the 7800 SERIES Relay Module.

**SERVICE NOTE:** Reset the 7800 SERIES Relay Module by pressing the reset push button on the relay module or pressing a remote reset push button wired through the Keyboard Display Module, Data ControlBus™ Module or Remote Reset Module. A power-up reset will cause an electrical reset of the 7800 SERIES Relay Module but will not reset a lockout condition.

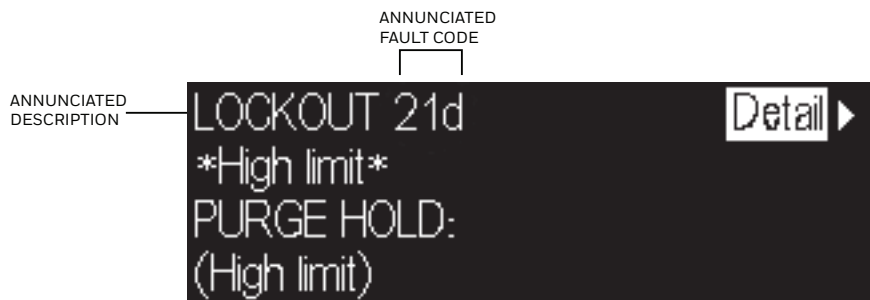
## Lockout Messages

When the 7800 SERIES is locked out, a standard lockout message is displayed unless the Call for Service feature is enabled. When the Call for Service feature is enabled a custom lockout message is displayed instead. The standard lockout message (see Fig. 22) is automatically displayed when the lockout initially occurs unless the user happens to be editing a parameter on a page. In this case the lockout message waits until the user is done editing and exits the page.



**Fig. 22. Lockout message**

Up to 4 lines are displayed in the standard lockout message. The top line shows the numeric fault code that determined the lockout. A description of this fault is shown on the second line and possibly on the third line if the description requires two lines to display it (only one line needed in the above example). On the next line(s) the burner control sequence state at the time of the lockout is displayed. The sequence state may need 1 or 2 lines to display (Fig. 22 required two lines). Since a maximum of 4 lines are displayed in this message, in the case when both the fault description and sequence state each need 2 lines to display their text, the second line of the sequence state is dropped to make room.



**Fig. 23. Annunciated lockout message**

When an annunciator is connected to the burner control system it may annunciate the lockout to provide more detailed information regarding the lockout. In this case the fault code is annunciated with a fault code letter and the fault description identifies more specifically the cause of the fault (see Fig. 23 for an example).

On the top line of the message the input focus is on a flashing “Detail” tab that permits the user to view more details about the lockout. Pressing the “Right arrow” or “OK” button navigates to a Lockout Detail page (see the following figure) that provides the following information:

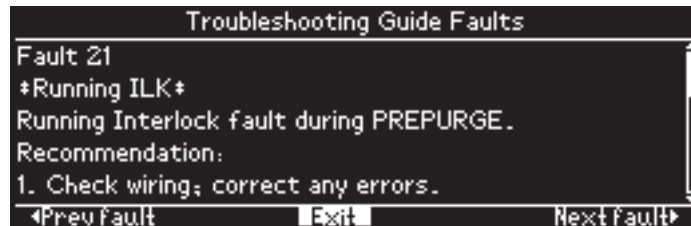
- Fault code
- Fault description
- Cycle count at the time of the fault
- Run-time hours at the time of the fault
- Sequence time at the time of the fault
- Operation sequence state at the time of the fault



**Fig. 24. Lockout detail**

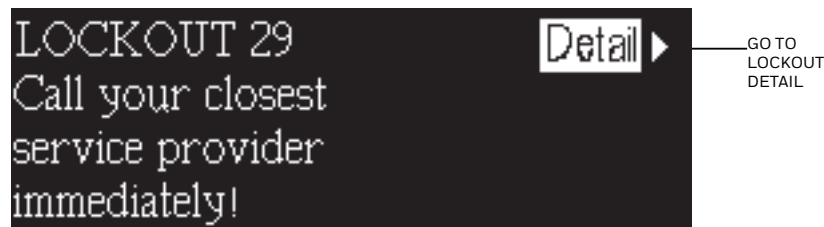
The information may take more lines to display than can fit on the 5 main body lines. In this case the a scroll bar is displayed, and the up and down arrow buttons can be used to scroll to view all lines.

A flashing “Troubleshoot” tab is displayed in the title bar that has input focus to indicate that the troubleshooting guide can be navigated to display what is recommended for this fault (see Fig. 25).



**Fig. 25. Troubleshooting guide**

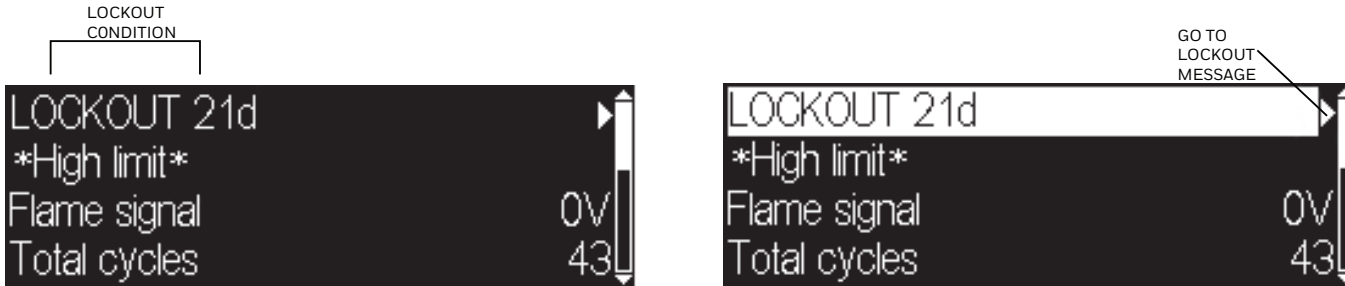
When the Call for Service feature is enabled a custom message up to 8 lines is displayed instead of the standard lockout message (see Fig. 26 for an example). Only 4 lines of the custom message are displayed at a time; the first 4 lines are displayed for 2 seconds, followed by the remaining lines for 2 seconds. The page alternates between these two sets of lines continuously. If the custom message is 4 lines or less, no alternation is needed.



**Fig. 26. Call for Service lockout message**

The first or top line of the message is not custom and is the same as the top line in the standard lockout message. This line permits the user to navigate to the Lockout Detail page.

The lockout message (standard or custom) displays continuously while the lockout condition persists. The user may elect to exit the message to view other pages by pressing the “Left arrow” or “Home” button which navigates to the Home page. The lockout condition is displayed on the Home page (see Fig. 27) which permits the user to re-display the lockout message. Pressing the “Right arrow” button when the lockout fault code line has input focus causes the lockout message to be re-displayed.



**Fig. 27. Lockout indication on Home page**

The following table describes the possible faults a burner control may have and the recommended action.

**Table 5. Fault Message Summary.**

<b>Fault Code</b>	<b>System Failure</b>	<b>Recommended Troubleshooting</b>
Fault 1 *No Purge Card*	No card is plugged into the purge card slot.	<ol style="list-style-type: none"> <li>1. Make sure the purge card is seated properly.</li> <li>2. Inspect the purge card and connector on the relay module for damage or contaminants.</li> <li>3. Reset and sequence the relay module.</li> <li>4. If the fault code reappears, replace the purge card.</li> <li>5. Reset and sequence the relay module.</li> <li>6. If the fault persists, replace the relay module.</li> </ol>
Fault 2 *AC Frequen/Noise	Excess noise or device running on slow ac.	<ol style="list-style-type: none"> <li>1. Check the relay module and display module connections.</li> <li>2. Reset and sequence the relay module.</li> <li>3. Check the relay module power supply and make sure that both frequency and voltage meet the specifications.</li> <li>4. Check the backup power supply, as appropriate.</li> </ol>
Fault 3 *AC Line Dropout	Ac line dropout detected.	
Fault 4 *AC Frequency*	Device running on fast ac.	
Fault 5 *Low Line Voltage*	Low ac line detected.	
Fault 6 *Purge Card Error*	Purge card timing changed since card was initially read.	<ol style="list-style-type: none"> <li>1. Make sure the purge card is seated properly.</li> <li>2. Inspect the purge card and connector on the relay module for damage or contaminants.</li> <li>3. Reset and sequence the relay module.</li> <li>4. If the fault code reappears, replace the purge card.</li> <li>5. Reset and sequence the relay module.</li> <li>6. If the fault persists, replace the relay module.</li> </ol>
Fault 7 *Flame Amplifier*	Flame sensed when flame not present.	<ol style="list-style-type: none"> <li>1. Check wiring and correct any errors. Make sure that the flame sensor wires are in separate conduits. Check for noise coupling into the flame detector leadwires.</li> <li>2. Make sure that flame detector and flame amplifier are compatible.</li> <li>3. Remove the flame amplifier and inspect connections. Reset the flame amplifier.</li> <li>4. Reset and sequence the relay module.</li> <li>5. If the code reappears, replace the amplifier.</li> <li>6. If the fault persists, replace the flame detector.</li> <li>7. If the fault persists, replace the relay module.</li> </ol>
Fault 8 *Flame Amp/Shutr*	Flame sensed when no signal expected during shutter-check or Ampli-Check™ versions.	

**Table 5. Fault Message Summary. (Continued)**

<b>Fault Code</b>	<b>System Failure</b>	<b>Recommended Troubleshooting</b>
Fault 9 *Flame Detected*	Flame sensed when no flame is expected during STANDBY.	<ol style="list-style-type: none"> <li>1. Check that flame is not present in the combustion chamber; correct any errors.</li> <li>2. Check wiring and correct any errors. Make sure that flame sensor wires are in separate conduits. Check for noise coupling into flame detector leadwires.</li> <li>3. Remove the flame amplifier and inspect its connections. Reset the amplifier.</li> <li>4. Reset and sequence the relay module.</li> <li>5. If the code reappears, replace the amplifier and/or the flame detector.</li> <li>6. If the fault persists, replace the flame detector.</li> <li>7. If the fault persists, replace the relay module.</li> </ol>
Fault 10 *Pre-Ignition ILK*	Pre-Ignition Interlock fault during STANDBY	<ol style="list-style-type: none"> <li>1. Check wiring and correct any errors.</li> <li>2. Check Pre-Ignition Interlock switches to assure proper functioning.</li> <li>3. Check fuel valve operation.</li> <li>4. Reset and sequence the relay module; monitor the Pre-Ignition Interlock status.</li> <li>5. If the code persists, replace the relay module.</li> </ol>
Fault 11 *Running ILK On*	Running Interlock powered at improper sequence point.	<ol style="list-style-type: none"> <li>1. Check wiring to make sure that interlocks are connected properly between terminals 6 and 7. Correct any errors.</li> <li>2. Reset and sequence the relay module.</li> <li>3. If the fault persists, measure the voltage between terminals 6 and L2(N) (ground), then terminals 7 and L2(N). If there is line supply voltage present at terminal 6 when the controller is off, the controller switch may be bad or jumpered.</li> <li>4. If steps 1 through 3 are correct and there is line supply voltage present at terminal 7 when the controller is closed and the fault persists, check for a welded or jumpered Running Interlock, Lockout Interlock, or Airflow Switch. Correct any errors.</li> <li>5. If steps 1 through 4 are correct and the fault persists, replace the relay module.</li> </ol>
Fault 12 *Lockout ILK On*	Lockout Interlock powered at improper sequence point.	
Fault 13 *Airflow Sw. On*	Combustion airflow interlock fault during STANDBY.	
Fault 14 *High Fire Sw.*	High Fire Interlock Switch failure to close during PREPURGE.	<ol style="list-style-type: none"> <li>1. Check wiring and correct any errors.</li> <li>2. Reset and sequence the relay module.</li> <li>3. Use either the manual motor potentiometer to drive the motor to the High Fire position or use the Run/Test Switch option, if available. Sequence to Prepurge drive to High Fire and place in the Test position. Adjust the High Fire Switch while in this state to make sure that it closes properly.</li> <li>4. Measure the voltage between terminal 19 and L2(N) while in the Prepurge drive to High Fire state. Line supply voltage should be present. If not, the switch adjustment is incorrect and/or the switch is defective and needs replacing.</li> <li>5. Reset and sequence the relay module. If the line supply voltage was present between the High Fire Switch and terminal 19, and the fault still persists, replace the relay module.</li> </ol>
Fault 15 *Flame Detected*	Flame sensed when no flame is expected during STANDBY.	<ol style="list-style-type: none"> <li>1. Check that the flame is not present in the combustion chamber; correct any errors.</li> <li>2. Make sure that the flame amplifier and flame detector are compatible.</li> <li>3. Check wiring and correct any errors.</li> <li>4. Remove the flame amplifier and inspect the connections. Reset the flame amplifier.</li> <li>5. Reset and sequence the relay module.</li> <li>6. If the code reappears, replace the amplifier and/or the flame detector.</li> <li>7. If the fault persists, replace the relay module.</li> </ol>

**Table 5. Fault Message Summary. (Continued)**

<b>Fault Code</b>	<b>System Failure</b>	<b>Recommended Troubleshooting</b>
Fault 16 *Flame-Out Timer*	No-flame detected during Pilot Flame Establishing Period.	<ol style="list-style-type: none"> <li>1. Measure the flame signal. If one exists, make sure it meets specifications. Make any necessary burner adjustments using manufacturer instructions.</li> <li>2. Make sure that the flame amplifier and flame detector are compatible.</li> <li>3. If the code reappears, replace the amplifier and/or the flame detector.</li> <li>4. If the fault persists, replace the relay module.</li> </ol>
Fault 17 *Main Flame Fail*	Main flame failure during RUN after flame is established an on for at least 10 seconds.	<ol style="list-style-type: none"> <li>1. Inspect the main fuel valve(s) and connection(s).</li> <li>2. Make sure that the fuel pressure is high enough to supply fuel to the combustion chamber.</li> <li>3. Check the flame detector sighting for adequate flame signal throughout the burner firing rate.</li> </ol>
Fault 18 *Flame Detected*	Flame sensed when the shutter is open and no flame is expected during PREPURGE.	<ol style="list-style-type: none"> <li>1. Check that flame is not present in the combustion chamber. Correct any errors.</li> <li>2. Make sure that the flame amplifier and flame detector are compatible.</li> <li>3. Check the wiring and correct any errors. Make sure F and G wires are in individual conduits and protected from stray noise pickup.</li> <li>4. Remove the flame amplifier and inspect the connectors. Reset the flame amplifier.</li> <li>5. Reset and sequence the relay module.</li> <li>6. If the code reappears, replace the flame amplifier and/or the flame detector.</li> <li>7. If the fault persists, replace the relay module.</li> </ol>
Fault 19 *Main Flame Ign.*	Flame was lost during MFEP or the first 10 seconds of the RUN state.	<ol style="list-style-type: none"> <li>1. Inspect the main fuel valve(s) and connection(s).</li> <li>2. Make sure the fuel pressure is high enough to supply fuel to the combustion chamber.</li> <li>3. Make sure the flame detector is positioned to obtain the required flame signal strength; reset and recycle.</li> </ol>
Fault 20 *Low Fire Sw. Off*	Low Fire Interlock switch failure to close during PREPURGE.	<ol style="list-style-type: none"> <li>1. Check wiring and correct any errors.</li> <li>2. Reset and sequence the relay module.</li> <li>3. Use either the manual motor potentiometer to drive the motor to the Low Fire position or use the Run/Test Switch option, if available. Sequence to Prepurge drive to Low Fire and place in the Test Position. Adjust the Low Fire Switch to make sure it closed properly.</li> <li>4. Measure the voltage between terminal 18 and L2(N) while in the Prepurge drive to Low Fire state. Line supply voltage should be present. If not, the switch adjustment is incorrect and/or the switch is defective and needs replacing.</li> <li>5. Reset and sequence the relay module. If line supply voltage was present between the Low Fire Switch and terminal 18, and the fault still persists, replace the relay module.</li> </ol>
Fault 21 *Running ILK*	Running Interlock fault during PREPURGE.	<ol style="list-style-type: none"> <li>1. Check wiring and correct any errors.</li> <li>2. Inspect the fan; make sure there is no blockage of the air intake and that it is supplying air.</li> <li>3. Make sure the Interlock Switches are working properly and that all switch contacts are free of contaminants.</li> <li>4. Reset and sequence the relay module to PREPURGE (place the Run/Test Switch in the Test position, if available). Measure the voltage between terminals 7 and L2(N). Line voltage should be present.</li> <li>5. If steps 1 through 4 are correct and the fault persists, replace the relay module.</li> </ol>
Fault 22 *Lockout ILK*	Lockout Interlock fault during PREPURGE.	
Fault 23 *Airflow Switch*	Combustion airflow interlock fault during PREPURGE.	
Fault 24 *Call Service*	The flame interlock (relay module) was on when it should be off.	<ol style="list-style-type: none"> <li>1. Check for F leadwire routing. Make sure routing is in its conduit and isolated from noise-producing circuits.</li> </ol>
Fault 25 *Call Service*	The flame interlock (relay module) was off when it should be on.	




**Table 5. Fault Message Summary. (Continued)**

<b>Fault Code</b>	<b>System Failure</b>	<b>Recommended Troubleshooting</b>
Fault 26 *Man-Open Sw. Off*	The Manual Open Valve Switch was off when it should be on (Device specific).	<ol style="list-style-type: none"> <li>1. Check wiring and correct any errors.</li> <li>2. Make sure that the Manual Open Valve Switch is fully open.</li> <li>3. Make sure that the Manual Open Valve Switch is functioning properly and that the switch contacts are free from contaminants.</li> <li>4. Reset and sequence the relay module.</li> <li>5. Make sure that the Manual Open Valve Switch provides an electrical path when closed. Verify that the relay module is receiving power at terminal 17.</li> <li>6. If steps 1 through 5 are correct and the fault persists, replace the relay module.</li> </ol>
Fault 27 *Start Switch On*	Start Switch was on during PREPURGE (Device specific).	<ol style="list-style-type: none"> <li>1. Start Switch held on too long.</li> <li>2. Check wiring; verify that Start Switch is correctly connected.</li> <li>3. Make sure that the Start Switch is functioning properly and that the switch contacts are free of contaminants.</li> <li>4. Reset and sequence the relay module to PREPURGE; set the Run/Test Switch to Test. Make sure there is no power at terminal 6 during PREPURGE.</li> <li>5. If steps 1 through 4 are correct and the fault persists, replace the relay module.</li> </ol>
Fault 28 *Pilot Flame Fail*	Pilot flame failure.	<ol style="list-style-type: none"> <li>1. Check pilot valve wiring and operation. Correct any errors.</li> <li>2. Check fuel supply.</li> <li>3. Check pilot pressure and repeat pilot turndown test.</li> <li>4. Check ignition transformer electrode, flame detector, flame detector sighting and flame amplifier.</li> <li>5. If steps 1 through 4 are correct and the fault persists, replace the relay module.</li> </ol>
Fault 29 *Lockout ILK*	Lockout Interlock fault.	<ol style="list-style-type: none"> <li>1. Check wiring and correct any errors.</li> <li>2. Inspect the fan; make sure that there is no blockage of the air intake and that it is supplying air.</li> <li>3. Make sure that the Lockout Interlock Switches are working properly and that all switch contacts are free from contaminants.</li> <li>4. Reset and sequence the relay module to PREPURGE (place the Run/Test Switch in the Test position, if available). Measure the voltage between terminals 7 and L2(N). Line voltage should be present.</li> <li>5. If steps 1 through 4 are correct and the fault persists, replace the relay module.</li> </ol>
Fault 30 *Running ILK*	Running Interlock fault.	<ol style="list-style-type: none"> <li>1. Inspect the Running Interlocks, including the Airflow Switch, and the connections.</li> <li>2. Make sure that the Running Interlocks, including the Airflow Switch, are functioning properly and that switch contacts are free from contaminants.</li> <li>3. Reset and sequence the relay module to PREPURGE. Set the Run/Test Switch, if available, to Test. Measure the voltage between terminal 7 and L2(N). Line voltage should be present.</li> <li>4. If steps 1 through 3 are correct and the fault persists, replace the relay module.</li> </ol>

**Table 5. Fault Message Summary. (Continued)**

<b>Fault Code</b>	<b>System Failure</b>	<b>Recommended Troubleshooting</b>
Fault 31 *Low Fire Sw. Off*	Low Fire Interlock Switch failure to close during RUN (Device specific).	<ol style="list-style-type: none"> <li>1. Check wiring and correct any errors.</li> <li>2. Reset and sequence the relay module.</li> <li>3. Use either the manual motor position to drive the motor to the Low Fire position, or use the Run/Test Switch option, if available. Sequence to Run drive to Low Fire and place the switch in the Test position. Adjust the Low Fire Switch while in this state to make sure it is closing properly.</li> <li>4. While in Run, drive to Low Fire state, measure the voltage between terminal 18 and L2(N). Line voltage should be present. If not, the switch adjustment is incorrect and/or the switch is defective and needs replacement.</li> <li>5. Reset and sequence the relay module. If line voltage was present between the Low Fire Switch and terminal 18, and the fault persists, replace the relay module.</li> </ol>
Fault 32 *Airflow Switch*	Combustion Airflow Interlock fault.	<ol style="list-style-type: none"> <li>1. Check wiring and correct any errors.</li> <li>2. Inspect the fan; make sure there is no blockage of the air intake and it is supplying air.</li> <li>3. Make sure the Airflow Interlock Switches are working properly and all switch contacts are free from contaminants.</li> <li>4. Reset and sequence the relay module to PREPURGE. Place the Run/Test Switch in the Test position, if available. Measure the voltage between terminals 7 and L2(N). Line voltage should be present.</li> <li>5. If steps 1 through 4 are correct and the fault persists, replace the relay module.</li> </ol>
Fault 33 *Pre-Ignition ILK*	Pre-Ignition Interlock fault.	<ol style="list-style-type: none"> <li>1. Check wiring and correct any errors.</li> <li>2. Inspect the Pre-Ignition Interlock switches and make sure they function properly.</li> <li>3. Check fuel valve operation. Valve must close within five seconds.</li> <li>4. Reset and sequence the relay module.</li> <li>5. During STANDBY or PREPURGE, measure the voltage between terminal 20 and L2(N). Line voltage should be present. If not, the Pre-Ignition Interlock switches can be defective and need replacing.</li> <li>6. If the fault persists, replace the relay module.</li> </ol>
Fault 34 *Control On*	CTL input was energized at the wrong time for the relay module. This fault implies a field wiring error.	<ol style="list-style-type: none"> <li>1. Check wiring and correct any errors.</li> <li>2. Reset and sequence the relay module.</li> <li>3. If fault persists, replace the relay module.</li> </ol>
Fault 35 *Call Service*	Safety relay was off when it should be on or the internal fuse has blown.	<ol style="list-style-type: none"> <li>1. Reset and sequence the relay module. If fault repeats, replace relay module, but be sure to test for excessive loads on appropriate terminals described by fault code.</li> </ol>
Fault 36 *Call Service*	Main valve terminal was off when it should be on, or the internal fuse has blown.	<ol style="list-style-type: none"> <li>2. If fault does not repeat on next cycle, check for electrical noise being coupled into the relay module through the loads on appropriate terminals described by the fault code.</li> </ol>
Fault 37 *Call Service*	Pilot (ignition) valve terminal was off when it should be on, or the internal fuse has blown.	<ol style="list-style-type: none"> <li>3. Possibly check for bouncing running on Lockout Interlock.</li> <li>4. If fault persists, replace the relay module.</li> </ol>
Fault 38 *Call Service*	Ignition terminal was off when it should be on, or the internal fuse has blown.	
Fault 39 *Call Service*	V2S valve terminal (usually terminal 21) was off when it should be on, or the internal fuse has blown.	
Fault 40 *Call Service*	Safety relay was on when it should be off.	

Table 5. Fault Message Summary. (Continued)

Fault Code	System Failure	Recommended Troubleshooting
Fault 41 *Main Valve On*	Main valve terminal was on when it should be off.	 <b>WARNING</b> <b>Explosion Hazard.</b> <b>Can cause severe injury, death or property damage.</b> 1. Remove system power, turn off fuel supply. 2. Check for wiring errors that could provide power to terminals described by the fault. Correct any errors. 3. Re-power system; reset and sequence the relay module. 4. If fault persists, replace the relay module. 5. When fault is corrected, turn on fuel supply.
Fault 42 *Pilot Valve On*	Pilot (ignition) valve terminal was on when it should be off.	
Fault 43 *Ignition On*	Ignition terminal was on when it should be off.	
Fault 44 *Pilot Valve 2 On*	V2S valve terminal, used as a pilot, is on when it should be off.	
Fault 45 *Low Fire Sw. Off*	Low Fire Interlock switch failure to close or stay closed.	<ol style="list-style-type: none"> <li>1. 1. Check wiring and correct any errors.</li> <li>2. 2. Reset and sequence the relay module.</li> <li>3. 3. Use either the manual motor position to drive the motor to the Low Fire position, or use the Run/Test Switch option, if available. Sequence to Run, drive to Low Fire and place in the Test position. Adjust the Low Fire Switch while in this state to make sure it is closing properly.</li> <li>4. 4. While in Run, drive to Low Fire state, measure the voltage between terminal 18 and L2(N). Line voltage should be present. If not, the switch adjustment is incorrect and/or the switch is defective and needs replacement.</li> <li>5. 5. If steps 1 through 4 are correct and the fault still persists, replace the relay module.</li> </ol>
Fault 46 *Flame Amp Type*	Device specific.	<ol style="list-style-type: none"> <li>1. Remove power to the device.</li> <li>2. Reset the flame amplifier and reset and sequence the relay module.</li> </ol>
Fault 47 *Jumpers Changed*	The configuration jumpers differ from the sample taken at startup.	<ol style="list-style-type: none"> <li>1. Inspect the jumper connections. Make sure that clipped jumpers are completely removed.</li> <li>2. Reset and sequence the relay module.</li> <li>3. If fault persists, replace the relay module.</li> </ol>
Fault 48 *Delayed MV On* (2nd Stage Valve)	V2S valve terminal, used as a delayed main valve, was on when it should be off.	 <b>WARNING</b> <b>Explosion Hazard.</b> <b>Can cause severe injury, death or property damage.</b> 1. Remove system power, turn off fuel supply. 2. Check wiring; correct any errors. 3. Inspect the V2S Fuel Valve and its connections. Make sure the switch is working correctly and is not jumpered or welded. 4. Reset and sequence the relay module. 5. If fault persists, replace the relay module.
Fault 49 *Man-Open Sw. On*	The manual open switch was on when it should be off.	 <b>WARNING</b> <b>Explosion Hazard.</b> <b>Can cause severe injury, death or property damage.</b> 1. Remove system power, turn off fuel supply. 2. Check wiring; correct any errors. 3. Inspect the Manual-Open Switch and its connections. Make sure the switch is working correctly and is not jumpered or welded. 4. Reset and sequence the relay module. 5. If fault persists, replace the relay module.
Fault 50 *Jumpers Wrong*	The sequence logic detected a combination of jumpers that is illegal for the sequence, e.g., if it is correct to clip jumper JR1 or Jumper JR2, but not both, this fault would be used when both are clipped (Device specific).	<ol style="list-style-type: none"> <li>1. Inspect the jumpers and refer to the installation instructions for compatible jumper configurations.</li> <li>2. Make sure that clipped jumpers are completely removed.</li> <li>3. Reset and sequence the relay module.</li> <li>4. If fault persists, replace the relay module.</li> </ol>

**Table 5. Fault Message Summary. (Continued)**

<b>Fault Code</b>	<b>System Failure</b>	<b>Recommended Troubleshooting</b>
Fault 51 *Flame Too Strong*	Flame signal value is too high to be valid.	<ol style="list-style-type: none"> <li>1. Make sure that flame detector and flame amplifier are compatible.</li> <li>2. Remove the flame amplifier and inspect the connections. Reset the flame amplifier.</li> <li>3. Reset and sequence the relay module.</li> <li>4. Check the flame detector sighting position, reset and cycle.</li> <li>5. Verify that no ignition noise is present in the F lead due to wire routing.</li> <li>6. Measure the flame strength. Verify it meets specifications. If not, refer the flame amplifier and/or flame detector checkout procedures.</li> <li>7. If the code reappears, replace the flame amplifier.</li> <li>8. If the code reappears, replace the flame detector.</li> <li>9. If the fault persists, replace the relay module.</li> </ol>
Fault 52 *Call Service*	Pilot Valve 2 (terminal 21) was off when it should be on.	<ol style="list-style-type: none"> <li>1. Inspect terminal 21 and connections. Make sure that the valve is operating properly.</li> <li>2. Reset and sequence the relay module.</li> <li>3. If the fault persists, replace the relay module.</li> </ol>
Fault 53 *Lockout Switch*	Lockout Input fault (EC/RM7850 only).	<ol style="list-style-type: none"> <li>1. Check wiring and correct any errors.</li> <li>2. Inspect the Lockout Switch to make sure it is working properly.</li> <li>3. Reset and sequence the relay module. During STANDBY or PREPURGE, measure the voltage between terminal 20 and L2(N). Supply voltage should be present. If not, the lockout switch is defective and needs replacing.</li> <li>4. If the fault persists, replace the relay module.</li> </ol>
Fault 54 *Comb. Pressure*	Combustion pressure switch fault (Fulton pulse only).	<ol style="list-style-type: none"> <li>1. Check wiring and correct any errors.</li> <li>2. Inspect the Combustion Pressure Switch to make sure it is working correctly.</li> <li>3. Reset and sequence the relay module.</li> <li>4. During STANDBY and PREPURGE, measure the voltage between terminal 20 and L2(N). Supply voltage should be present. If not, the Combustion Pressure Switch is defective and needs replacing.</li> <li>5. If the fault persists, replace the relay module.</li> </ol>
Fault 55 *Purge Fan Sw. On*	Purge fan switch is on when it should be off (Fulton pulse only).	<ol style="list-style-type: none"> <li>1. Check wiring and correct any errors.</li> <li>2. Inspect the Purge Fan Switch terminal 18 and its connections. Make sure the switch is working correctly and is not jumpered or welded.</li> <li>3. Reset and sequence the relay module.</li> <li>4. If the fault persists, replace the relay module.</li> </ol>
Fault 56 *Block Intake*	Block intake fault (Fulton pulse only).	<ol style="list-style-type: none"> <li>1. Check wiring and correct any errors.</li> <li>2. Inspect the Block Intake Switch and make sure it is working properly.</li> <li>3. Reset and sequence the relay module.</li> <li>4. During PREPURGE, measure the voltage between terminal 7 and L2(N). Supply voltage should be present. If not, the Block Intake Switch is defective and needs replacing.</li> <li>5. If the fault persists, replace the relay module.</li> </ol>
Fault 57 *Purge Fan Sw. Off*	Purge Fan Switch is off when it should be on (Fulton pulse only).	<ol style="list-style-type: none"> <li>1. Inspect the Prepurge Fan Switch terminal 18 and the connections. Make sure the fan is working properly.</li> <li>2. Reset and sequence the relay module.</li> <li>3. If the fault persists, replace the relay module.</li> </ol>
Fault 58 - 60 *Call Service*	Unused faults.	—
Fault 61	MV1 Off (Terminal 9); should be ON.	<ol style="list-style-type: none"> <li>1. Check wiring and correct any errors.</li> <li>2. Reset and sequence the control.</li> <li>3. If fault persists, replace relay module (Before installing the new relay module, verify current draw of terminal 9).</li> </ol>

**Table 5. Fault Message Summary. (Continued)**

<b>Fault Code</b>	<b>System Failure</b>	<b>Recommended Troubleshooting</b>
Fault 62	MV2 Off (Terminal 17); should be ON.	<ol style="list-style-type: none"> <li>1. Check wiring and correct any errors.</li> <li>2. Reset and sequence the control.</li> <li>3. If fault persists, replace relay module (Before installing the new relay module, verify current draw of terminal 17).</li> </ol>
Fault 63	MV1 ON (Terminal 9); should be OFF.	<ol style="list-style-type: none"> <li>1. Check wiring and correct any errors.</li> <li>2. Reset and sequence the control.</li> <li>3. If fault persists, replace relay module (Before installing the new relay module, verify current draw of terminal 9).</li> </ol>
Fault 64	MV2 ON (Terminal 17); should be OFF.	<ol style="list-style-type: none"> <li>1. Check wiring and correct any errors.</li> <li>2. Reset and sequence the control.</li> <li>3. If fault persists, replace relay module (Before installing the new relay module, verify current draw of terminal 17).</li> </ol>
Fault 65 *VPS Off*	Valve Proving Switch (Terminal 16) OFF; should be ON. (VPS High Test)	<ol style="list-style-type: none"> <li>1. Check wiring and correct any errors.</li> <li>2. Check MV2 for leaking valve seat.</li> <li>3. Reset and sequence control.</li> </ol>
Fault 66 *VPS On*	Valve Proving Switch (Terminal 16) ON; should be OFF. (VPS Low Test)	<ol style="list-style-type: none"> <li>1. Check wiring and correct any errors.</li> <li>2. Check MV1 for leaking valve seat.</li> <li>3. Reset and sequence control.</li> </ol>
Fault 67 *AC Phase*	L1 and L2 miswired/exchanged (EC/RM7850 only).	<ol style="list-style-type: none"> <li>1. Check L1 and L2 for proper line phasing.</li> </ol>
Fault 68 *Pre-Ignition ILK*	Pre-Ignition Interlock fault.	<ol style="list-style-type: none"> <li>1. Check wiring and correct any errors.</li> <li>2. Inspect the Pre-Ignition Interlock switches and make sure they work properly.</li> <li>3. Check fuel valve operation. Valve must close within five seconds.</li> <li>4. Reset and sequence the relay module.</li> <li>5. During STANDBY or PREPURGE, measure the voltage between terminal 17 and L2(N). Supply voltage should be present. If not, the Pre-Ignition Interlock switches are defective and need replacing.</li> <li>6. If the fault persists, replace the relay module.</li> </ol>
Faults 69 - 70 *Call Service*	Unused faults.	—
Fault 71 *Dynamic LFS*	Low Fire Switch closed, High Fire Switch must be open (EC/RM 7850 only).	<ol style="list-style-type: none"> <li>1. Check firing rate position switches (usually in Modutrol® Motor) for proper operation.</li> <li>2. Check wiring and correct any errors.</li> <li>3. Reset and sequence the relay module.</li> <li>4. If the fault persists, replace the relay module.</li> </ol>
Fault 71 *Limits Complete*	Limit Input (terminal 7) is off when it should be on (RM7888 only).	<ol style="list-style-type: none"> <li>1. Check limits to make sure they are satisfied after resetting.</li> <li>2. Check electrical connections to terminal 7 of wiring sub-base.</li> <li>3. Reset relay module.</li> <li>4. If the fault persists, replace the relay module.</li> </ol>
Fault 72 *Dynamic HFS*	High Fire Switch closed; Low Fire Switch must be open (EC/RM7850 only).	<ol style="list-style-type: none"> <li>1. Check firing rate position switches (usually in Modutrol® Motor) for proper operation.</li> <li>2. Check wiring and correct any errors.</li> <li>3. Reset and sequence the relay module.</li> <li>4. If the fault persists, replace the relay module.</li> </ol>
Fault 72 *Spec.Func.2*	Special Function 2 Input (terminal 17) is off when it should be on (Device specific).	<ol style="list-style-type: none"> <li>1. Check operation of Special Function 2 of PLC.</li> <li>2. Check electrical connection to terminal 17 of wiring sub-base and confirm presence of supply power when Special Function 2 is activated.</li> <li>3. Reset relay module.</li> <li>4. If the fault persists, replace the relay module.</li> </ol>

**Table 5. Fault Message Summary. (Continued)**

<b>Fault Code</b>	<b>System Failure</b>	<b>Recommended Troubleshooting</b>
Fault 73 *Spec.Func.3*	Special Function 3 Input (terminal 19) is off when it should be on (Device specific).	<ol style="list-style-type: none"> <li>1. Check operation of Special Function 3 of PLC.</li> <li>2. Check electrical connection to terminal 19 of wiring sub-base and confirm presence of supply power when Special Function 2 is activated.</li> <li>3. Reset relay module.</li> <li>4. If the fault persists, replace the relay module.</li> </ol>
Fault 75 *Flame Proven Feedback*	Flame Indication Feedback (terminal 21) either on when it should be off or off when it should be on (Device specific).	<ol style="list-style-type: none"> <li>1. Remove wire to terminal 21 and reset relay module.</li> <li>2. If the fault persists, replace relay module.</li> <li>3. Reconnect wire to terminal 21. If the fault returns, verify wiring.</li> </ol>
Faults 76 - 87 *Accessory Fault*	—	—
Fault 88 *Accessory Fault*	T17 powered without Valve Proving feature setup.	<ol style="list-style-type: none"> <li>1. Follow Valve Proving Selection Setup in Appendix B on selected Relay Module.</li> <li>2. If No Valve Proving (NEVER) is required, connect controller (Demand) to terminal 6.</li> </ol>
Fault 89 *Accessory Fault*	T6 and T17 powered at the same time.	<ol style="list-style-type: none"> <li>1. Correct wiring error.</li> </ol>
Fault 90 *Accessory Fault*	T7 opens on RM7890 with VPS Feature	<ol style="list-style-type: none"> <li>1. Determine what interrupted terminal 7.</li> <li>2. Correct any wiring issues.</li> <li>3. Reset Relay Module.</li> </ol>
Faults 91-93 *Accessory Fault	—	<ol style="list-style-type: none"> <li>1. —</li> </ol>
Faults 94 - 104 *Call Service*	—	—
Fault 105 *Call Service*	Relay Module self-test failure.	<ol style="list-style-type: none"> <li>1. Reset and sequence the relay module.</li> <li>2. If the fault reappears, remove power from the relay module and reapply the power; reset and sequence the relay module.</li> <li>3. If the fault persists, replace the relay module.</li> </ol>
Fault 106 *Call Service*	Relay Module self-test failure.	—
Fault 107 *Call Service*	Relay Module flame signal crosscheck failure.	—
Fault 108 *Call Service*	Lost E2 or device shipped unprogrammed.	<ol style="list-style-type: none"> <li>1. Reset control; if fault persists, replace control.</li> <li>2. If device resets and operates, verify earth grounding practices.</li> </ol>
Fault 109 *Call Service*	Negative cycle test failed, earth ground absent or line voltage phasing improper.	<ol style="list-style-type: none"> <li>1. Make sure a good earth ground connection exists at the installation site and all earth ground connections are complete and correct.</li> <li>2. Make sure the relay module and all loads operate at the same line voltage phase.</li> <li>3. Reset and sequence the relay module.</li> <li>4. If the fault persists, replace the relay module.</li> </ol>

Table 5. Fault Message Summary. (Continued)

Fault Code	System Failure	Recommended Troubleshooting
Fault 110 *Call Service*	The configuration jumpers differ from stored values.	<ol style="list-style-type: none"> <li>1. Inspect the jumper connections. Make sure they match the original selection and clipped jumpers are completely removed.</li> <li>2. Reset and sequence the relay module.</li> <li>3. If the fault persists, replace the relay module.</li> <li>4. Configuration jumpers must be selected prior to 200 hours of operation. If configuration jumpers are changed after 200 hours of operation, lockout 110 occurs. Relay module <i>cannot</i> be reset and <i>must</i> be replaced.</li> </ol>
Fault 111 *Call Service*	Relay Module configuration jumper test failure.	<ol style="list-style-type: none"> <li>1. Inspect the jumper connections. Make sure they match the original selection and clipped jumpers are completely removed.</li> <li>2. Reset and sequence the relay module.</li> <li>3. If the fault persists, replace the relay module.</li> </ol>
Fault 112 - 126 *Call Service*	Relay Module self-test failure.	<ol style="list-style-type: none"> <li>1. Reset and sequence the relay module.</li> <li>2. If the fault persists, replace the relay module.</li> </ol>
Fault 127 *Call Service*	Safety relay feedback circuit was in an improper state.	<ol style="list-style-type: none"> <li>1. Reset and sequence the relay module.</li> <li>2. If the fault persists, replace the relay module.</li> </ol>

## Expanded Annunciator Messages

If an Expanded Annunciator is wired to the limit control and interlock control strings, and connected to the 7800 SERIES Relay Module, additional hold messages, fault messages or code numbers enhance the original hold messages, fault messages or code numbers. See the Expanded Annunciator specification, form 65-0101, for detailed information. The message demonstrates which device opened first in a monitored string of limits or interlocks.

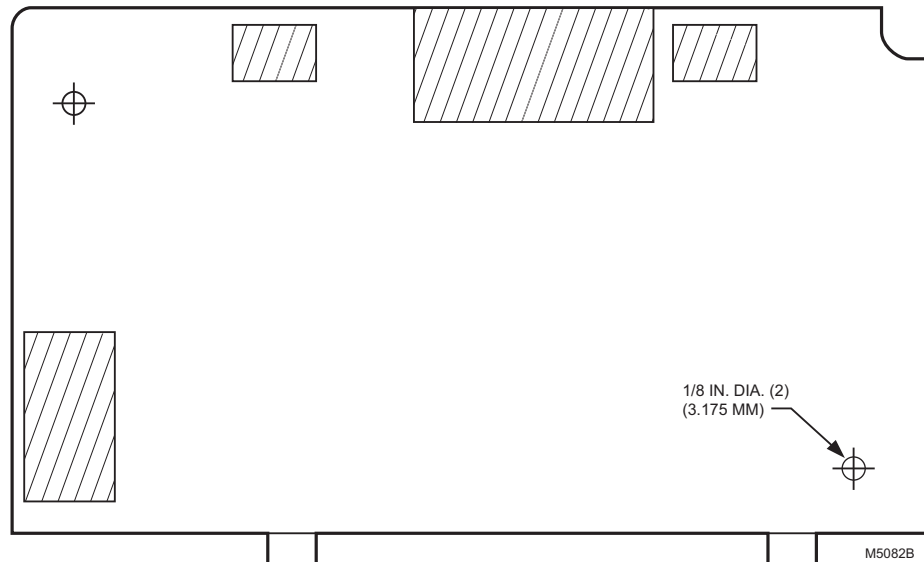


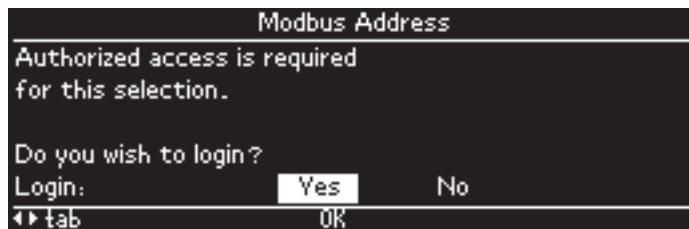
Fig. 28. KDM flush mounting outline.

## APPENDIX A: DISPLAY SETUP

The S7800A1142 display module permits the following features to be configured:

- Call for Service custom lockout message
- Modbus interface
  - Enable
  - Address
  - Baud rate
  - Parity
  - U32 register Endian order
- Annunciator terminal assignment
- Custom annunciator terminal messages
- Sleep time
- Inactivity time
- Selected status message (for Home page)
- Backlight intensity level
- Language
- Heater mode

The current settings of these parameters can be viewed at any time, but to change their setting values an authorized login with the display password is required. When the user attempts to change a parameter setting (requests navigation to the edit page for the parameter) and the user is not currently logged in, a warning is displayed indicating that a login is required (see Fig. 29).



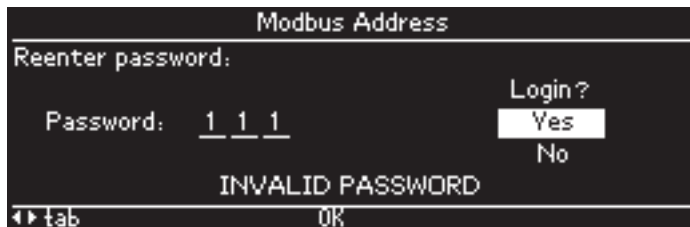
**Fig. 29. Login required**

If the user is authorized to change configuration settings, knows the display password, and wishes to continue with the parameter change, the user presses the OK button with the input focus on the “Yes” selection. If the user isn’t authorized to change the parameter or doesn’t want to change it, the user tabs to the “No” selection with the right arrow or left arrow button and presses the OK button. Control returns back to the previous page if the user elects to not make the parameter change. If the user elects to change the parameter setting, the user is asked to login (see Fig. 30).



**Fig. 30. Display login**

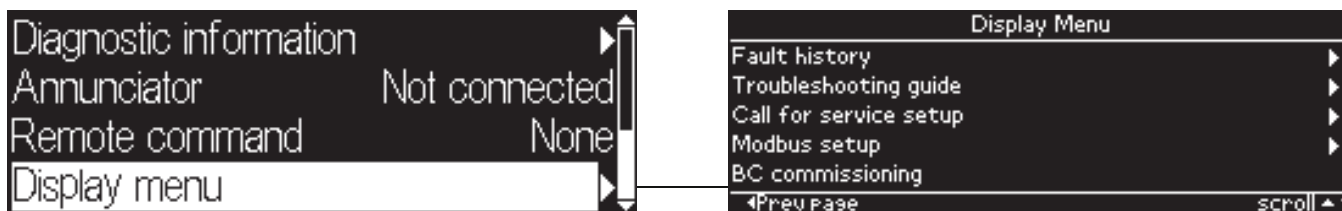
The 3-digit display password is entered by scrolling the digits and tabbing to the “Yes” command and pressing the OK button to login. A successful login transitions to the configuration page. An unsuccessful login (wrong password) displays an “INVALID PASSWORD” message (see Fig. 31). If the user elects to cancel the login, tabbing to the “No” command and pressing the OK button returns control to the previous page.



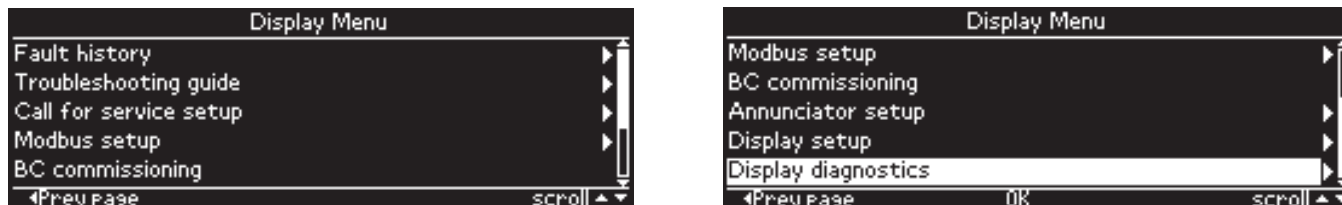
**Fig. 31. Invalid login**

A successful login is active for all pages navigated to while staying within the configuration pages. When the display module returns back to the Home or Lockout page the login status is negated and future parameter changes will require the user to login again.

Navigating to these display setup functions starts from the “Display menu” selection on the Home page (see Fig. 32). The Display Menu page allows the user to scroll to the function desired.



**Fig. 32. Navigate to Display Menu**

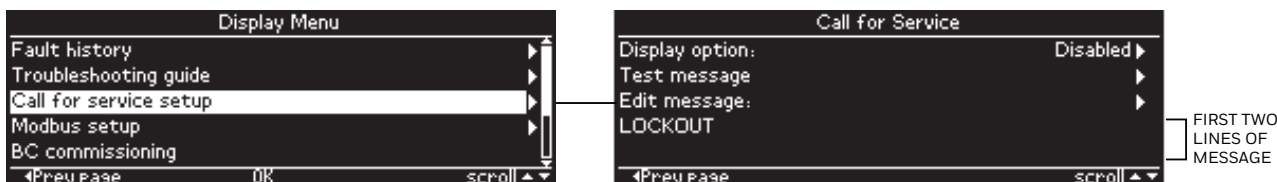


**Fig. 33. Display Menu**

**Call for Service Setup**

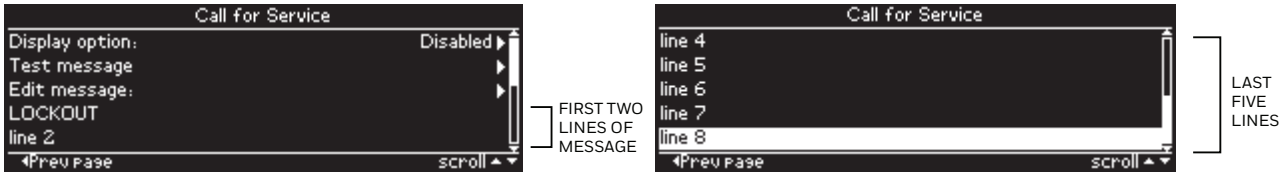
Setup of the Call for Service lockout message feature is accessed from the Display Menu (see the Fig. 34). The feature permits a custom message to be displayed in place of the standard lockout message. The custom message can be up to 8 lines of 20 characters per line. The first line is not editable and matches with the first line of the standard lockout message.

First line of call for service message matches standard lockout message so that the lockout detail command can be positioned on the line.



**Fig. 34. Call for Service setup menu**

The lines of the message are displayed on the menu, and if more than 2 lines are in the message, the last lines can be seen by scrolling down the page (see Fig. 35).



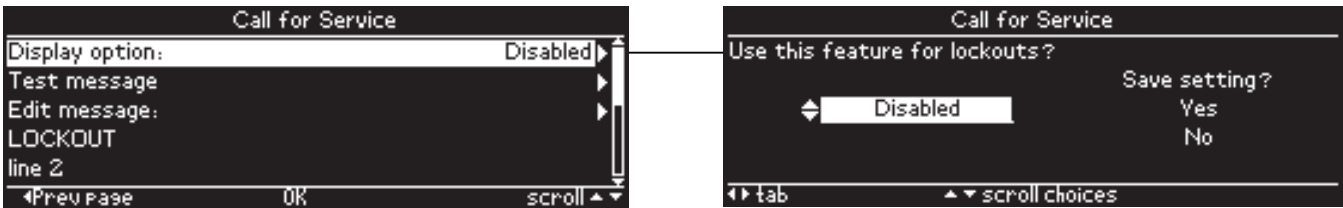
**Fig. 35. Call for Service message**

The up and down arrow buttons are used to scroll through the menu lines. A “Next page” symbol is displayed on the menu line if it is selectable for an action (all menu lines except for the message itself). When a selectable menu line has focus (is highlighted) and the right arrow or OK button is pressed, the following actions occur:

- “Display option” – enable/disable this feature
- “Test message” – view message in operation
- “Edit message” – edit the message

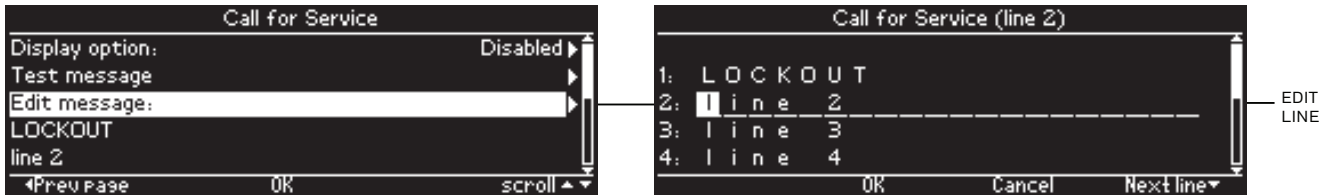
The user must be logged in before navigation to the “Display option” and “Edit message” pages occur. If the user is not logged in, the user is asked to log in. The left arrow button is used to exit this page and return back to the Display Menu page. The Home button exits this page and goes to the Home page.

The Call for Service feature is turned on (enabled) or off (disabled) by editing the “Display option” (see next figure). The up and down arrow buttons are used to scroll to the desired setting: “Enabled” or “Disabled”. To commit the change the right arrow button is used to tab to the “Yes” command and the OK button is pressed to save the selected setting. If the setting should not be saved, scroll down to the “No” command and press the OK button. In both cases control returns back to the Call for Service menu.



**Fig. 36. Enable/disable Call for Service**

Changing the contents of the message is initiated by selecting the “Edit message” line (see Fig. 37). Since the first line of the message is fixed, i.e., not editable, the input focus is positioned on the first character position of the second line. Up to 20 characters can be entered for each line. Up to 7 lines (excluding the first line) can be edited, lines 2 through 8. Lines at the bottom that are blank are not displayed in the message. The current message text is displayed when the page is initially entered.

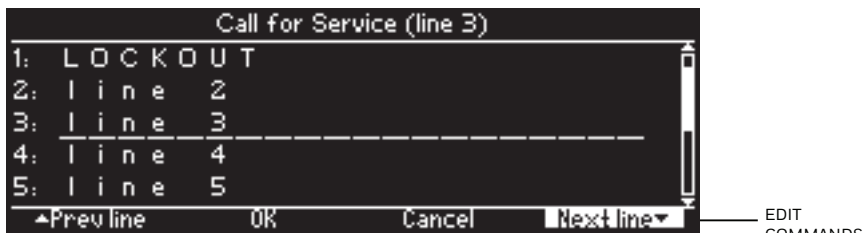


**Fig. 37. Edit Call for Service message**

The title displays which line of the message currently is being edited in addition to the line number displayed on the left side of the edit line. Up to 5 lines of the message is displayed in the page main body area. The line being edited is always positioned in the center of the main body with the text characters underlined and is called the “edit line”. When the input focus is on the “edit line” the message text can be edited. The up and down arrow buttons are used to scroll through the alphabet to choose the character for each text character. The up and down arrow buttons can be pressed and held to repeatedly scroll the characters. The right and left arrow buttons are used to change the input focus to each character position in the line.

The navigation bar at the bottom of the edit page has commands that are selectable for the following functions (see Fig. 38):

- “Prev line” – go up to previous message line (line above)
- “OK” – accept and save message text changes (exit this page)
- “Cancel” – do not save any message text changes (exit this page)
- “Next line” – go to next message line (line below)

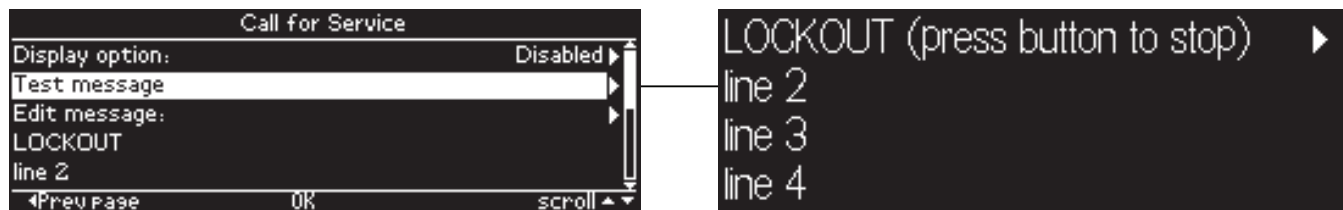


**Fig. 38. Call for Service edit commands**

The edit commands are accessed from the edit line from either the first or last character positions. When the input focus is on the first character position of the edit line a left arrow button action navigates the input focus down to the navigation bar commands. When the input focus is on the last character position in the edit line a right arrow button action also moves down to the navigation bar.

The right and left arrow buttons are used to tab between the edit commands on the navigation bar. Pressing the OK button causes the highlighted command to be executed. When the “OK” or “Cancel” command is executed the edit page is exited and control returns back to the Call for Service menu. Pressing the up or down arrow button from the command line navigates the input focus back to the edit text line.

The message can be tested to see what it would look like when a lockout occurs by selecting the “Test message” line (see Fig. 39). The message continuously displays until the user presses any button to stop. After a button is pressed and released the simulation is stopped and control returns back to the Call for Service menu.



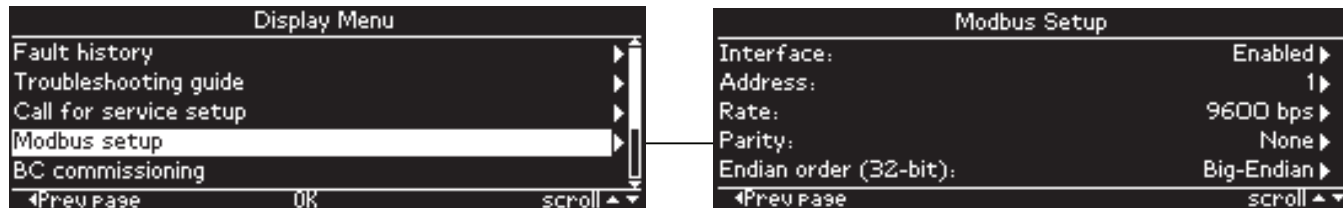
**Fig. 39. Call for Service test message**

The lockout fault code is not displayed in the first line, but instead a message to press any button to stop the test is given.

### Modbus Setup

Modbus setup is accessed from the Display Menu (see Fig. 40). The current settings of the following Modbus parameters are displayed:

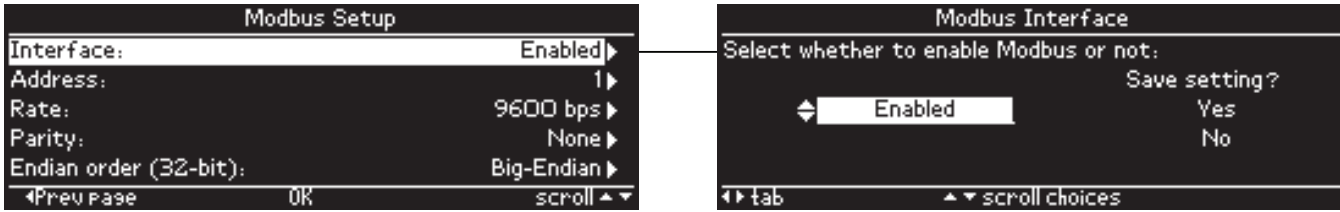
- Interface enable/disable option
- Slave address
- Baud rate (speed)
- Parity
- Endian order (for 32-bit registers)



**Fig. 40. Modbus setup menu**

The up and down arrow buttons are used to scroll down to the line of the parameter to edit. Pressing the right arrow or OK button navigates to the parameter edit page (unless a display login is required first). Pressing the left arrow button exits this page and returns back to the Display menu.

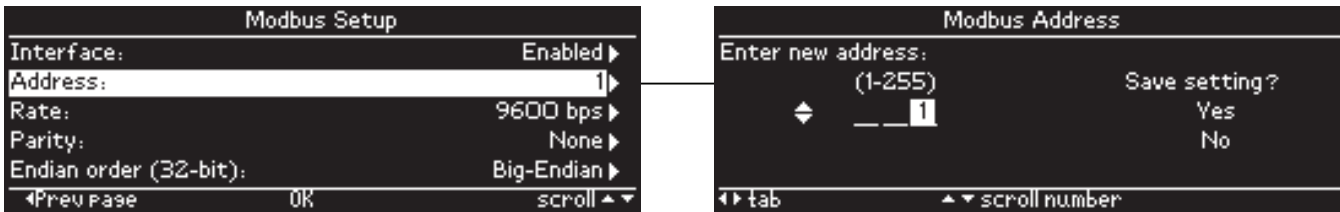
The Modbus interface can be enabled or disabled by selecting the “Interface” line and pressing the right arrow or OK button (see Fig. 41). When the interface is enabled the RS-485 pins of the edge connector (terminals 1-3) accepts Modbus communication requests as a Modbus slave. When the interface is disabled the RS-485 pins provide a communication bus for other 7800 SERIES accessories (see “Wiring” on page 5). The current enable setting is displayed initially.



**Fig. 41. Modbus interface setup**

The up and down arrow buttons are used to scroll between the two options: “Enabled” and “Disabled”. To commit the change the right arrow button is used to tab to the “Yes” command and the OK button is pressed to save the selected setting. If the setting should not be saved, scroll down to the “No” command and press the OK button. In both cases control returns back to the Modbus setup menu.

The Modbus slave address can be edited by selecting the “Address” line and pressing the right arrow or OK button (see Fig. 42). Only Modbus messages directed to this address are acknowledged and messages sent to other addresses are ignored by this display module. An address range of 1-255 can be configured. The current address setting is displayed when the page is initially entered.



**Fig. 42. Modbus address setup**

The up and down arrow buttons are used to increment/decrement the slave address digits on the edit line. The right and left arrow buttons are used to tab between the address digit positions and the save commands on the right, “Yes” and “No”. When the input focus is on the save commands the up and down arrow buttons scroll between “Yes” and “No”. When the address is set to the value desired the “Yes” command is selected and the OK button is pressed to commit the change. If the user decides not to save the displayed address, the “No” command is selected and the OK button is pressed. In both save command cases the control returns back to the Modbus setup menu.

The Modbus baud rate (speed) can be edited by selecting the “Rate” line and pressing the right arrow or OK button (see Fig. 43). The baud rate can be set to one of the following speeds:

- 4800 bps
- 9600 bps
- 19200 bps
- 38400 bps
- 57600 bps
- 115200 bps

The current baud rate setting is displayed when the page is initially entered.



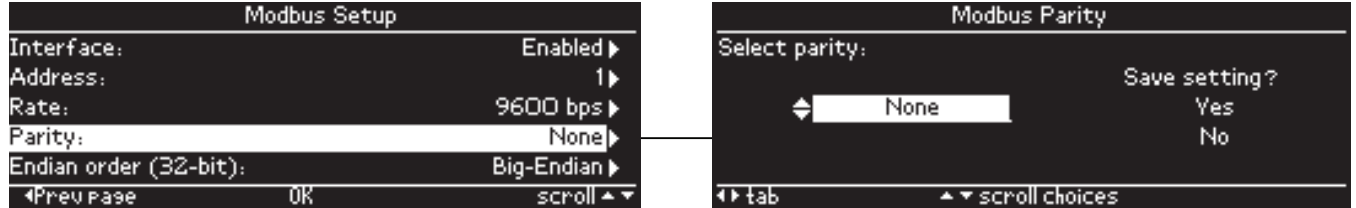
**Fig. 43. Modbus baud rate setup**

The up and down arrow buttons are used to scroll through the speed choices on the edit line. The right and left arrow buttons are used to tab to the save commands, “Yes” and “No”. When the input focus is on the save commands the up and down arrow buttons scroll between “Yes” and “No”. When the speed is set to the value desired the “Yes” command is selected and the OK button is pressed to commit the change. If the user decides not to save the displayed speed, the “No” command is selected and the OK button is pressed. In both save command cases control returns back to the Modbus setup menu.

The Modbus parity can be edited by selecting the “Parity” line and pressing the right arrow or OK button (see Fig. 44). The Modbus interface can be configured for one of the following parity types:

- Even parity
- Odd parity
- No parity (None)

The current parity setting is displayed initially when the page is entered.



**Fig. 44. Modbus parity setup**

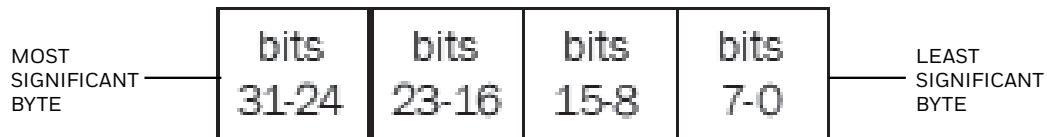
The up and down arrow buttons are used to scroll through the parity choices on the edit line. The right and left arrow buttons are used to tab to the save commands, “Yes” and “No”. When the input focus is on the save commands the up and down arrow buttons scroll between “Yes” and “No”. When the parity choice is set to the value desired the “Yes” command is selected and the OK button is pressed to commit the change. If the user decides not to save the displayed parity setting, the “No” command is selected and the OK button is pressed. In both save command cases the control returns back to the Modbus setup menu.

The Endian data order for 32-bit registers in the Modbus interface (designated by U32 in Format column of Table 16) can be specified by selecting the “Endian order” line and pressing the right arrow or OK button (see Fig. 45).

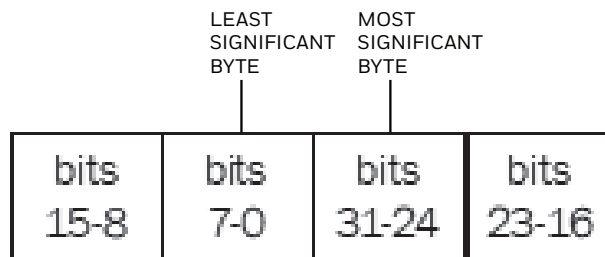


**Fig. 45. Modbus Endian order setup**

The data order can be set to “Big-Endian” or “Little-Endian”. A Big-Endian setting is used when the Modbus response provides the 32-bit data in the following order:



A Little-Endian setting is used when the Modbus response provides the 32-bit data in the following order:



Default setting is Big-Endian, but the current setting is displayed when the page is initially entered.

The up and down arrow buttons are used to scroll between the two options on the edit line. The right and left arrow buttons are used to tab to the save commands, “Yes” and “No”. When the input focus is on the save commands the up and down arrow buttons scroll between “Yes” and “No”. When the order choice is set to the value desired the “Yes” command is selected and the OK button is pressed to commit the change. If the user decides not to save the displayed order setting, the “No” command is selected and the OK button is pressed. In both save command cases control returns back to the Modbus setup menu.

## Annunciator Setup

Annunciator setup is accessed from the Display Menu (see Fig. 46). This setup permits the customization of the annunciator interface to match with the system usage of the annunciator. Two selections are possible from this menu:

- Terminal assignment
- Custom messages

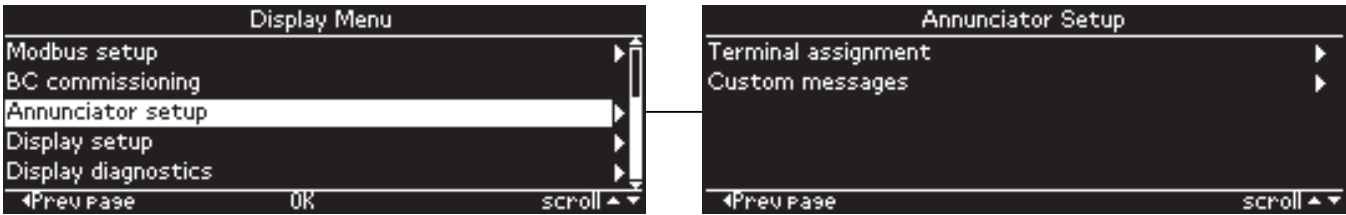


Fig. 46. Annunciator setup

Terminal assignment allows the user to name the annunciator terminals to match with their system interlock purpose. These assignments can be edited by selecting the “Terminal assignment” line and pressing the right arrow or OK button (see Fig. 47). Each terminal, 4-22, can be named from one of the messages in Table 7. When the page is initially displayed the current terminal assignments are displayed.



Fig. 47. Annunciator terminal assignment setup

Note that terminal 19 has two different names, one for gas and one for oil. The page displays next to the terminal number which one is referenced (see Fig. 48).

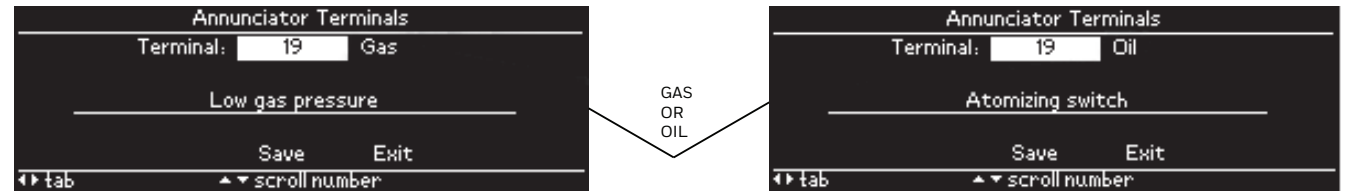


Fig. 48. Annunciator terminal T19

The up and down arrow buttons are used to scroll through the terminal numbers when the input focus is on the terminal selection line. As the terminal number changes the current name assigned for the terminal is displayed. The right and left arrow buttons on this line are used to navigate to the name selection line (see Fig. 49).

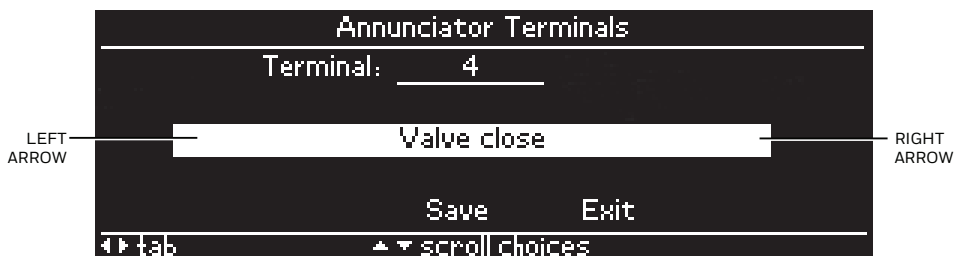
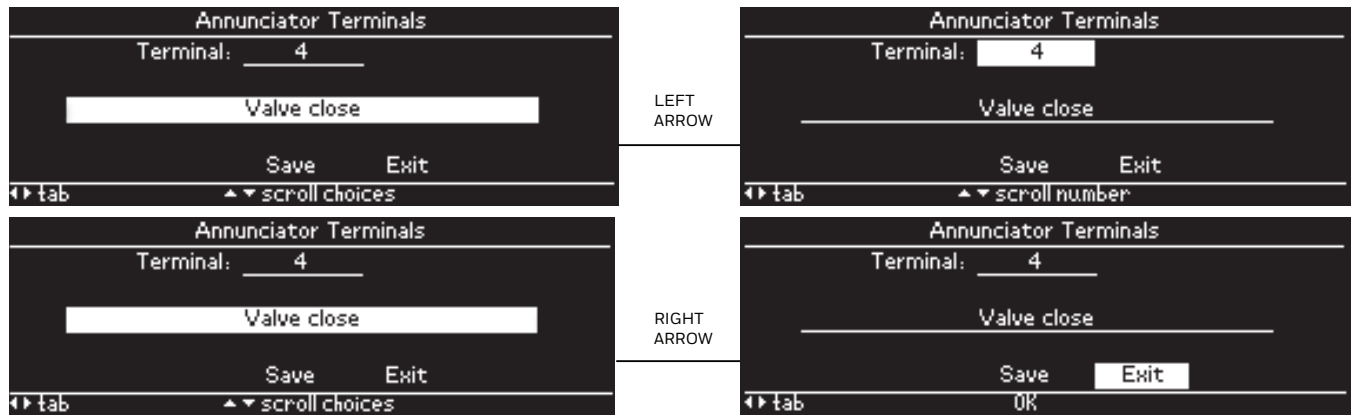


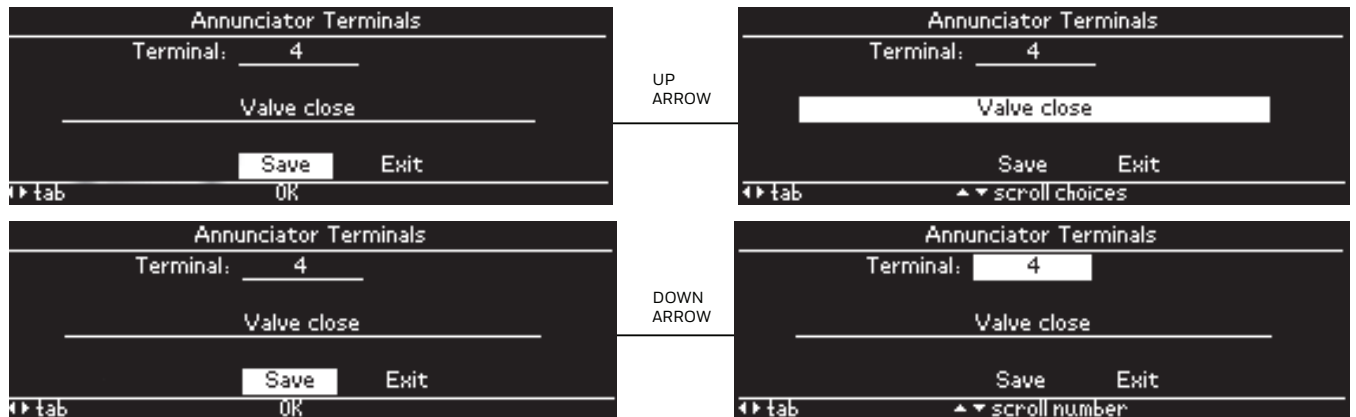
Fig. 49. Annunciator terminal name selection line

On the name selection line the up and down arrows are used to scroll through the names that are listed in Table 7. When the desired name for the terminal is displayed the name can be committed by navigating to the “Save” command on the command line. The right arrow button tabs to the “Exit” command from the name selection line (see Fig. 50) while the left arrow button tabs up to the terminal selection line.



**Fig. 50. Tab from annunciator terminal name selection line**

On the command line the right and left arrow buttons tab between the “Save” and “Exit” commands. Pressing the OK button executes the command that is highlighted. The “Save” command saves the currently displayed terminal assignment to permanent storage in the display module. The “Exit” command leaves this page and returns back to the Annunciator setup menu. Pressing the up arrow button on the command line navigates up to the name selection line, and pressing the down arrow button “wraps around” to the terminal selection line (see Fig. 51).



**Fig. 51. Tab from annunciator terminal command line**

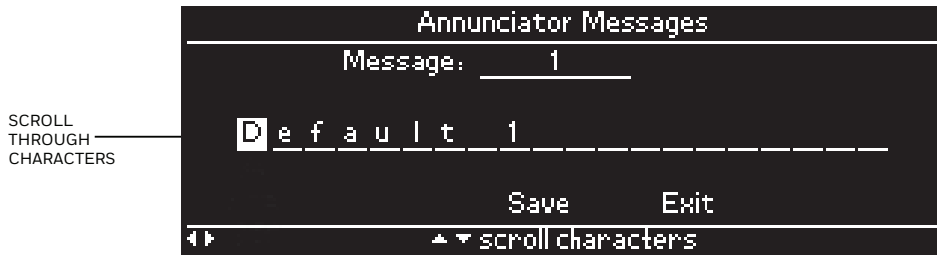
Custom annunciator messages allow the user to define names that are different from the fixed names listed in Table 7. Up to 20 custom messages can be used with each message allowing for 20 characters. These messages can be edited by selecting the “Custom messages” line and pressing the right arrow or OK button (see Fig. 52). Each custom message, 1-20, initially displays the current text that the message contains.

The up and down arrow buttons are used to scroll through the message numbers, 1-20, on the message number line. As the message number changes the message text for the message number is displayed. The right and left arrow buttons are used to navigate to the text edit line.



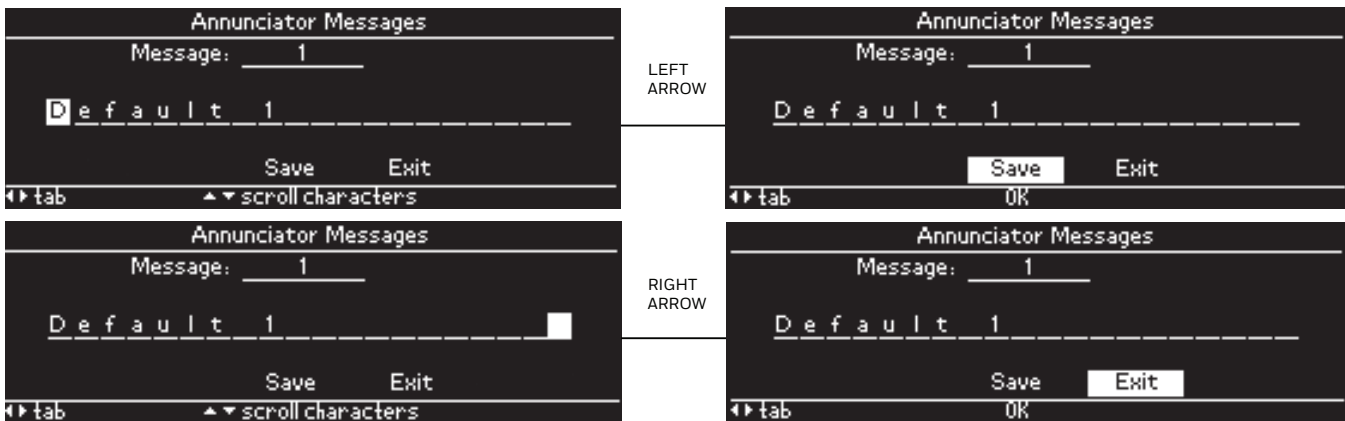
**Fig. 52. Annunciator custom messages setup**

On the text edit line (see Fig. 53) the up and down arrow buttons are used to scroll through the alphabet characters in the message text. The up and down arrow buttons can be pressed and held to repeatedly scroll the characters.



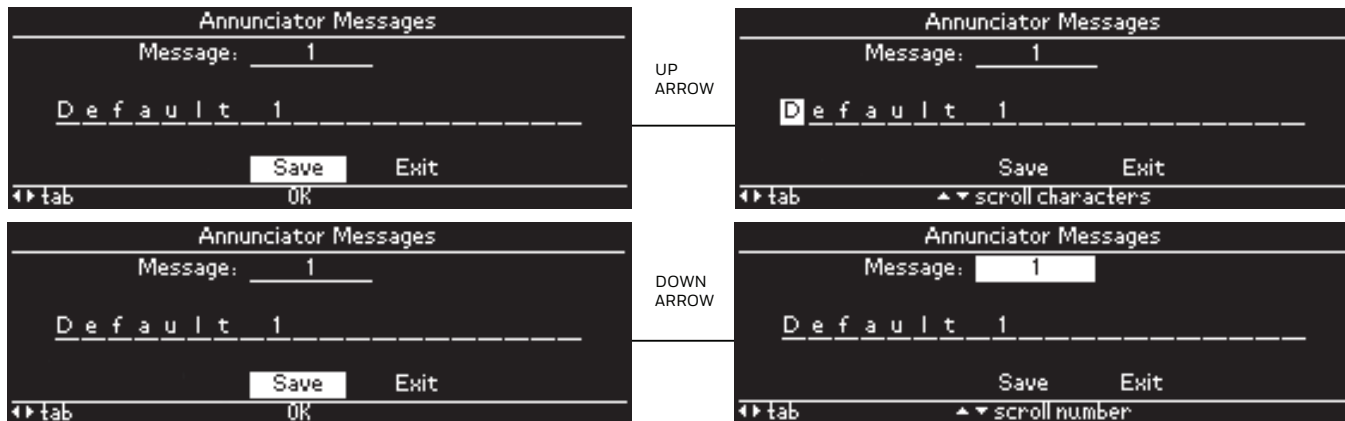
**Fig. 53. Scroll annunciator custom message characters**

The right and left arrow buttons move the input focus between the character positions in the text. When the left arrow button is pressed and the input focus is in the first character position of the text, however, the input focus moves to the "Save" command in the command line (see Fig. 54). When the right arrow button is pressed and the input focus is in the last character position of the text, the input focus moves to the "Exit" command in the command line.



**Fig. 54. Tab to annunciator custom message command line**

On the command line the left and right arrow buttons are used to tab between the "Save" and "Exit" commands. When the OK button is pressed and the "Save" command is highlighted, the displayed text is saved for the custom message number in permanent storage of the display module. When the OK button is pressed and the "Exit" command is highlighted, this page is exited and control returns back to the Annunciator setup menu. The up arrow button is used on the command line to navigate back up to the text edit line, and the down arrow button is used to "wrap round" to the message number line (see Fig. 55).



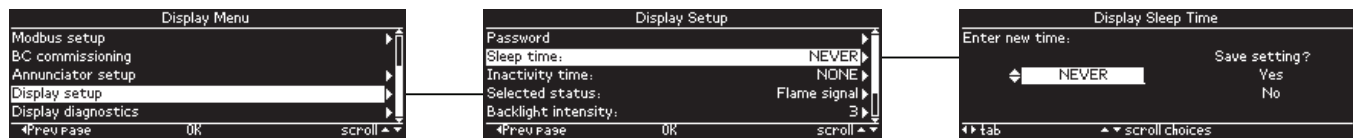
**Fig. 55. Tab from annunciator custom message command line**

## Sleep Time

The display sleep time determines whether the LCD in the display module should go blank or not after a period of time when no user activity occurs with the device. The display sleep time can be set to one of the following settings:

- Never (don't ever go to sleep)
- 5 seconds
- 10 seconds
- 30 seconds
- 1 minute
- 5 minutes
- 1 hour

Sleep time setup is accessed from the Display Setup Menu (see Fig. 56). The current parameter setting is displayed when the page is initially entered.



**Fig. 56. Display sleep time setup**

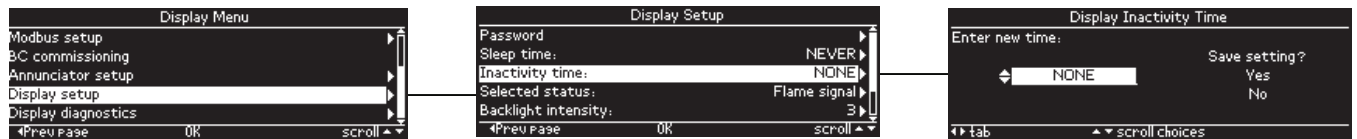
The up and down arrow buttons are used to scroll through the time choices on the edit line. The right and left arrow buttons are used to tab to the save commands, “Yes” and “No”. When the input focus is on the save commands the up and down arrow buttons scroll between “Yes” and “No”. When the time is set to the value desired the “Yes” command is selected and the OK button is pressed to commit the change. If the user decides not to save the displayed time, the “No” command is selected and the OK button is pressed. In both save command cases control returns back to the Display setup menu.

## Inactivity Time

The display inactivity time determines whether any non-status (configuration, etc.) page should be automatically exited after a period of time of no user activity on the display module (no button presses). If this parameter is enabled, any page other than the Home, Lockout, and diagnostics pages are automatically exited if the page is idle for the time specified by this parameter. The intent of this parameter is to not leave the display on a configuration page after the user has left the display module vicinity to prevent any unauthorized changes to a parameter setting. The following settings can be selected for this parameter:

- None (do not automatically exit any page)
- 30 seconds
- 1 minute
- 5 minutes
- 30 minutes
- 1 hour

Inactivity time setup is accessed from the Display Setup Menu (see Fig. 57). The current parameter setting is displayed when the page is initially entered.



**Fig. 57. Display inactivity time setup**

The up and down arrow buttons are used to scroll through the time choices on the edit line. The right and left arrow buttons are used to tab to the save commands, “Yes” and “No”. When the input focus is on the save commands the up and down arrow buttons scroll between “Yes” and “No”. When the time is set to the value desired the “Yes” command is selected and the OK button is pressed to commit the change. If the user decides not to save the displayed time, the “No” command is selected and the OK button is pressed. In both save command cases control returns back to the Display setup menu.

## Selected Status Message

The selected status message feature permits the Home page to be customized to display a status item on it that is of interest for the installation. The selected status item is displayed on a line below the burner control sequence state on the Home page (above “Flame signal” line). This message can be chosen from the list contained in the next table.

**Table 6. Selectable Messages.**

<b>Selectable Message/Display</b>	<b>Description</b>	<b>Possible States/Range (Terminals)</b>	<b>Comments</b>
Flame signal	Flame signal strength.	0 - 5.0 Vdc Flame Amp (+ and - (Com))	Flame relay pull-in and dropout value 1.25 Vdc.
Total cycles	Total number of equipment operating cycles.	0 - 99,999 (250,000; 999,999 <sup>c</sup> ) cycles <sup>a</sup>	Cycle will be updated each time main valve is energized.
Total hours	Total number of equipment operating hours.	0 - 99,999 (250,000; 999,999 <sup>c</sup> ) hours <sup>a</sup>	Hour will be updated each time main valve output is energized for 60 minutes.
FH fault code	Number that identifies the reason for lockout.	0-127	Most recent fault in fault history.
FH cycle	Cycle when fault occurred.	0 - 99,999 (250,000; 999,999 <sup>c</sup> ) cycles <sup>a</sup>	Most recent fault in fault history.
FH hours	Run hour when fault occurred.	0 - 99,999 (250,000; 999,999 <sup>c</sup> ) hours <sup>a</sup>	Most recent fault in fault history.
FH message	Indicates cause of lockout.		Most recent fault in fault history.
FH seq state	Indicates where in the sequence when the lockout occurred.		Most recent fault in fault history.
FH seq time	Indicates time in the sequence when the lockout occurred.		Most recent fault in fault history.
Device type	Device type number.	RM78XXX, R7140, or EC78XXX	
Run/Test switch	Position of Run/Test switch.	RUN or TEST	Indicates if 7800 SERIES is in RUN or TEST mode.
T6 terminal <sup>e</sup>	Burner control T6 terminal I/O state.	ON or OFF	Indicates if input is on or off, energized or de-energized.
T7 terminal <sup>e</sup>	Burner control T7 terminal I/O state.	ON or OFF	Indicates if input is on or off, energized or de-energized.
T8 terminal <sup>e</sup>	Burner control T8 terminal I/O state.	ON or OFF	Indicates if input is on or off, energized or de-energized.
T9 terminal <sup>e</sup>	Burner control T9 terminal I/O state.	ON or OFF	Indicates if input is on or off, energized or de-energized.
T10 terminal <sup>e</sup>	Burner control T10 terminal I/O state.	ON or OFF	Indicates if input is on or off, energized or de-energized.
T16 terminal <sup>e</sup>	Burner control T16 terminal I/O state.	ON or OFF	Indicates if input is on or off, energized or de-energized.
T17 terminal <sup>e</sup>	Burner control T17 terminal I/O state.	ON or OFF	Indicates if input is on or off, energized or de-energized.
T18 terminal <sup>e</sup>	Burner control T18 terminal I/O state.	ON or OFF	Indicates if input is on or off, energized or de-energized.
T19 terminal <sup>e</sup>	Burner control T19 terminal I/O state.	ON or OFF	Indicates if input is on or off, energized or de-energized.
T20 terminal <sup>e</sup>	Burner control T20 terminal I/O state.	ON or OFF	Indicates if input is on or off, energized or de-energized.
T21 terminal <sup>e</sup>	Burner control T21 terminal I/O state.	ON or OFF	Indicates if input is on or off, energized or de-energized.

Table 6. Selectable Messages. (Continued)

Selectable Message/Display	Description	Possible States/Range (Terminals)	Comments
Jumper 1	Pilot Flame Establishing Period (PFEP).	INTACT/CLIPPED	Display shows state of PFEP jumper. If jumper is intact, 7800 SERIES was 10 second PFEP. If jumper is clipped, 7800 SERIES has 4 second PFEP.
	First Safety Time (for RM/EC7850).	INTACT/CLIPPED	Display shows state of First Safety Time (EC7850) jumper. If jumper is intact, EC7850 has 5 second First Safety Time. If jumper is clipped, the EC7850 has 3 second First Safety Time.
Jumper 2	Pilot Valve.	INTACT/CLIPPED	Display shows state of PilotValve (terminal no. 21). If jumper is intact, RM7800G has Intermittent Pilot Valve. If jumper is clipped, RM7800G has 15 or 30 second Interrupted Pilot Valve.
	Main Trial Time (for RM/EC7850).	INTACT/CLIPPED	Display shows state of Main Trial Time (EC7850)Valve (terminal no. 21). If jumper is intact, EC7850 has 5 second Main Trial Time. If jumper is clipped, EC7850 has 3 second Main Trial Time.
Jumper 3	Start-up Airflow Switch (AFS) check.	INTACT (Disabled) / CLIPPED (Enabled)	Display shows state of Start-up AFS check jumper. If jumper is clipped, RM7800 AFS check is enabled and if jumper is intact, AFS check is disabled.
Flame amp type	Defines type of amplifier installed.	STANDARD/AMP-CHECK/SHUTTER	Display shows type of flame detection system installed (i.e., as STANDARD, AMP-CHECK/AMPLI-CHECK™ and SHUTTER/ Dynamic Self-Checking).
Flame response	Amplifier Flame Failure Response Time (FFRT) in seconds.	0.8 second, 1 second, 2 seconds, or 3 seconds	
Purge time	Timing value of purge card.	mm:ss	Two seconds to 30 minutes.
Manu code	Postpurge time (enhanced models only).	mm:ss	Zero seconds to 63 minutes.
SW revision	Software revision of burner control module.		
Annun status	Current annunciator status.		
T4 Proof of closure <sup>f</sup>	Annunciator Proof of closure.	ON or OFF	Indicates if interlock is on or off.
T5 Valve closure <sup>f</sup>	Annunciator Valve closure.	ON or OFF	Indicates if interlock is on or off.
T6 Op control <sup>f</sup>	Annunciator Operating control.	ON or OFF	Indicates if interlock is on or off.
T7 Aux Limit 1 <sup>f</sup>	Annunciator Auxiliary Limit #1.	ON or OFF	Indicates if interlock is on or off.
T8 Aux Limit 2 <sup>f</sup>	Annunciator Auxiliary Limit #2.	ON or OFF	Indicates if interlock is on or off.
T9 LWCO <sup>f</sup>	Annunciator Low Water Cutoff.	ON or OFF	Indicates if interlock is on or off.
T10 High limit <sup>f</sup>	Annunciator High limit.	ON or OFF	Indicates if interlock is on or off.
T11 Aux Limit 3 <sup>f</sup>	Annunciator Auxiliary Limit #3.	ON or OFF	Indicates if interlock is on or off.

**Table 6. Selectable Messages. (Continued)**

Selectable Message/Display	Description	Possible States/Range (Terminals)	Comments
T12 Oil select <sup>f</sup>	Annunciator Oil selection.	ON or OFF	Indicates if interlock is on or off.
T13 High oil pressure <sup>f</sup>	Annunciator High oil pressure.	ON or OFF	Indicates if interlock is on or off.
T14 Low oil pressure <sup>f</sup>	Annunciator Low oil pressure.	ON or OFF	Indicates if interlock is on or off.
T15 High oil temp <sup>f</sup>	Annunciator High oil temperature.	ON or OFF	Indicates if interlock is on or off.
T16 Low oil temp <sup>f</sup>	Annunciator Low oil temperature.	ON or OFF	Indicates if interlock is on or off.
T17 Gas select <sup>f</sup>	Annunciator Gas selection.	ON or OFF	Indicates if interlock is on or off.
T18 High gas pressure <sup>f</sup>	Annunciator High gas pressure.	ON or OFF	Indicates if interlock is on or off.
T19 Low gas pressure <sup>f</sup>	Annunciator Low gas pressure.	ON or OFF	Indicates if interlock is on or off.
T19 Atomizing <sup>f</sup>	Annunciator Atomizing switch.	ON or OFF	Indicates if interlock is on or off.
T20 Airflow <sup>f</sup>	Annunciator Airflow switch.	ON or OFF	Indicates if interlock is on or off.
T21 Aux ILK 4 <sup>f</sup>	Annunciator Auxiliary ILK #4.	ON or OFF	Indicates if interlock is on or off.
T22 Aux ILK 5 <sup>f</sup>	Annunciator Auxiliary ILK #5.	ON or OFF	Indicates if interlock is on or off.
Annun fault code	Annunciator fault code.		
Annun SW revision	Annunciator software revision.		

<sup>a</sup>European approved controls

<sup>b</sup>Pre-ignition Interlock terminal 17 or 20 is model dependent.

<sup>c</sup>Valve Proving device or RM7897

<sup>d</sup>Display values are as follows:

- n represents a numbered value
- T represents a terminal number
- x represents the suffix letter of the Relay module

<sup>e</sup>Burner control terminal name is displayed.

<sup>f</sup>Assigned annunciator terminal name is displayed.

Editing of this feature is accessed by selecting “Selected status” from the Display Setup menu (see Fig. 58). The current parameter setting is displayed when the page is initially entered.



**Fig. 58. Selected status message setup**

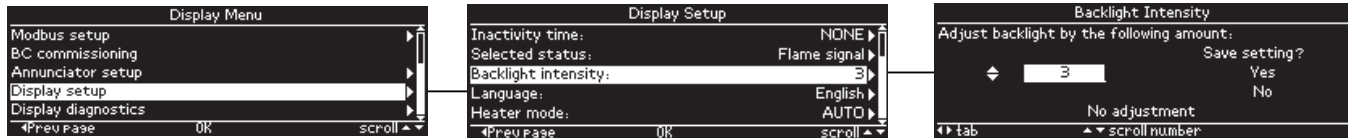
The up and down arrow buttons are used to scroll through the message choices on the edit line. The right and left arrow buttons are used to tab to the save commands, “Yes” and “No”. When the input focus is on the save commands the up and down arrow buttons scroll between “Yes” and “No”. When the message is set to the value desired the “Yes” command is selected and the OK button is pressed to commit the change. If the user decides not to save the displayed message choice, the “No” command is selected and the OK button is pressed. In both save command cases control returns back to the Display setup menu.

## Backlight Intensity Level

The backlight intensity level specifies the intensity that the LCD backlight should have at this installation location. The following intensity levels can be specified:

- 5 = Brightest
- 4 = Brighter
- 3 = Normal (no adjustment) – default
- 2 = Slightly darker
- 1 = Darker
- 0 = Darkest

Access to setup this parameter is obtained from the Display setup menu (see Fig. 59). Current adjustment level setting is displayed when the page is initially entered.



**Fig. 59. Backlight intensity level setup**

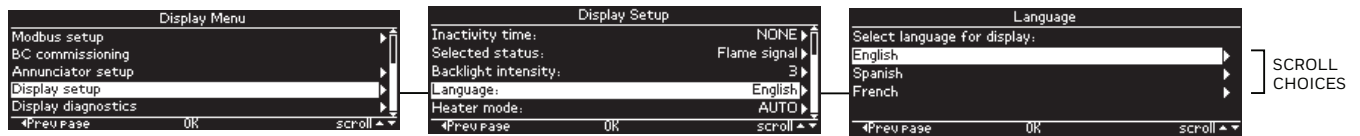
The up and down arrow buttons are used to scroll through the adjustment levels on the edit line. The right and left arrow buttons are used to tab to the save commands, “Yes” and “No”. When the input focus is on the save commands the up and down arrow buttons scroll between “Yes” and “No”. When the level is set to the desired value the “Yes” command is selected and the OK button is pressed to commit the change. If the user decides not to save the displayed level, the “No” command is selected and the OK button is pressed. In both save command cases control returns back to the Display setup menu.

## Language

The language to use for the display module can be selected from one of the following:

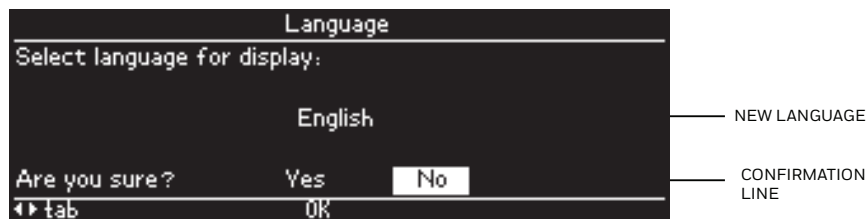
- English (default)
- Spanish
- French

Setup of the language to use is accessed from the Display setup menu (see Fig. 60). The line for the current language setting is highlighted on the page.



**Fig. 60. Language setup**

The up and down arrow buttons are used to scroll between the possible selections and highlight the one the user wants. The left arrow button is used to exit this page and not make any language change (page is exited and control returns back to Display setup menu). The right arrow or OK button is pressed to set the language to the highlighted line. A final confirmation is asked (see Fig. 61) before committing to the new language setting.



**Fig. 61. Language change confirmation**

The right and left arrow buttons are used on the confirmation line to tab between “Yes” and “No” options. Pressing the OK button executes the highlighted option. When “Yes” is executed the display module switches to the new language. When “No” is executed the language change is canceled and the language remains as it is. In both cases control returns back to the Language setup menu.

## Heater Mode

Heater panel operation can be set by the user to one of the following settings:

- Automatic (default) – heater turns on when internal temperature reaches 0°C or below
- On – heater is on always
- Off – heater is off always

Heater mode setup is accessed from the Display setup menu (see Fig. 62). The current setting is displayed when the page is initially entered.

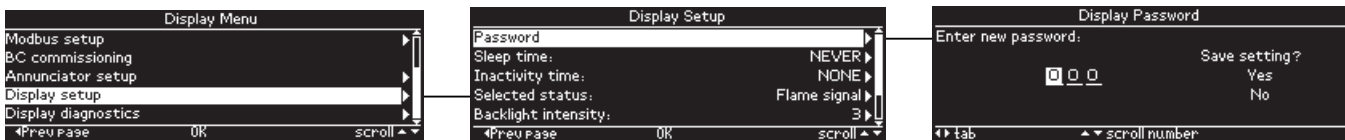


**Fig. 62. Heater mode setup**

The up and down arrow buttons are used to scroll through the mode settings on the edit line. The right and left arrow buttons are used to tab to the save commands, “Yes” and “No”. When the input focus is on the save commands the up and down arrow buttons scroll between “Yes” and “No”. When the mode is set to the desired value the “Yes” command is selected and the OK button is pressed to commit the change. If the user decides not to save the displayed mode, the “No” command is selected and the OK button is pressed. In both save command cases control returns back to the Display setup menu.

## Display Password

The display module password can be edited to a new 3-digit setting. Password setup is accessed from the Display setup menu (see Fig. 63).



**Fig. 63. Display password setup**

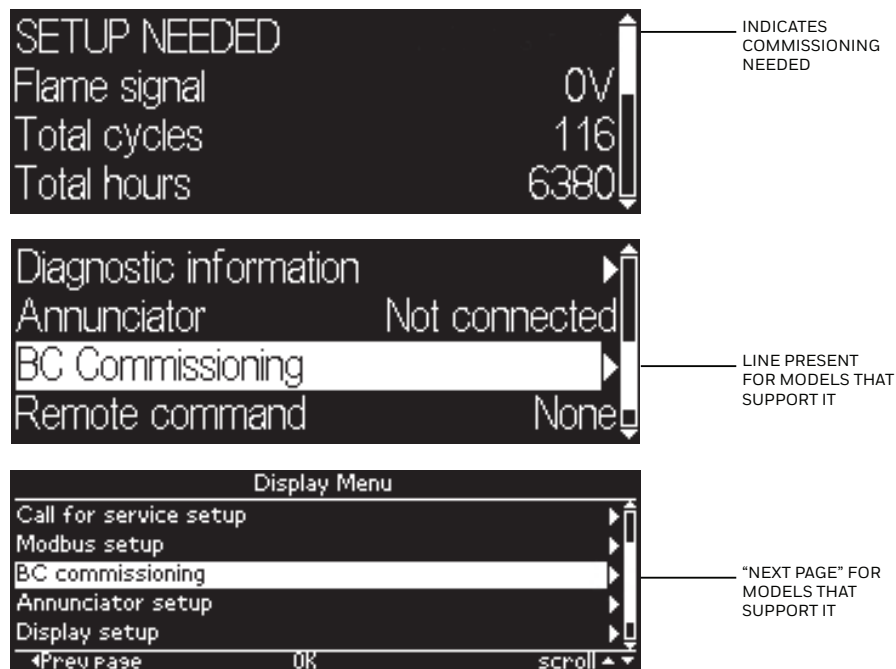
## APPENDIX B: BURNER CONTROL COMMISSIONING

The S7800 display module is required to commission the following features in 7800 SERIES burner control modules that support them:

- Valve proving system
- Post purge timing

Not all 7800 modules support these features. Some models may support both features while some may only support one or the other. These safety features are configured using a commissioning procedure that interacts with the installed burner control module. The commissioning procedure is driven by the burner control module since it is aware of the features it supports and is responsible for their settings. Models that support either one of the features can be identified in the display module by one of three methods (see Fig. 64):

- “SETUP NEEDED” state is displayed on the Home page
- “BC Commissioning” line is present on the Home page
- “BC Commissioning” line is enabled for navigation on the Display setup menu page



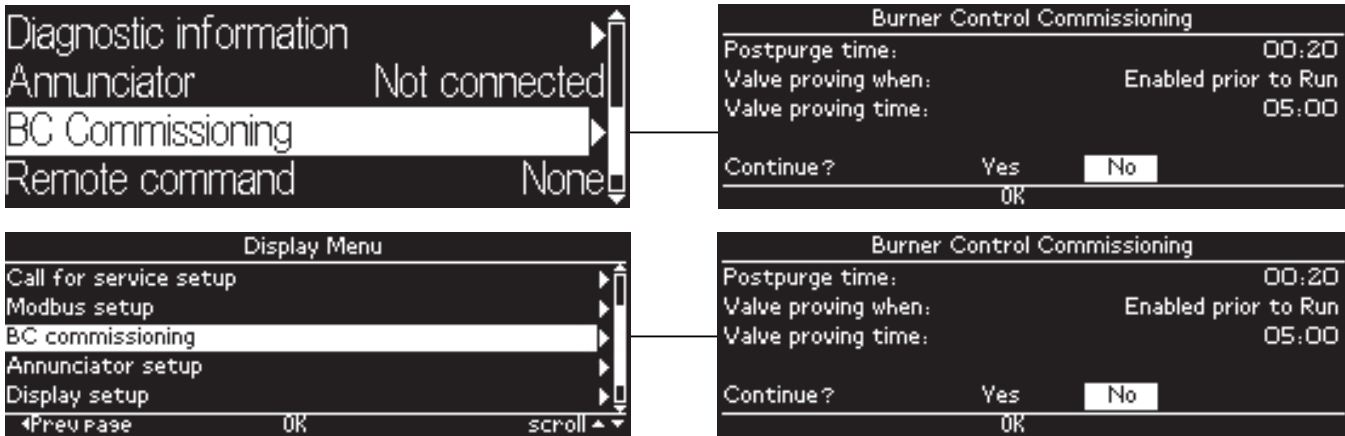
**Fig. 64. Commissioning applicable for burner control module**

When “SETUP NEEDED” is displayed on the Home page the burner control module will not fire until commissioning is performed. Commissioning can only be performed when the burner control module is in this condition or when it is locked out or in a STANDBY state. Commissioning is not allowed when the burner control module is in any other state. “BC Commissioning” line is only present on the Home page when the burner control module supports it *and* it is in one of the states listed above.

Commissioning is initiated from either the Home or Display Menu pages (see Fig. 65). The BC commissioning setup menu displays showing the current settings of the three possible commissionable parameters:

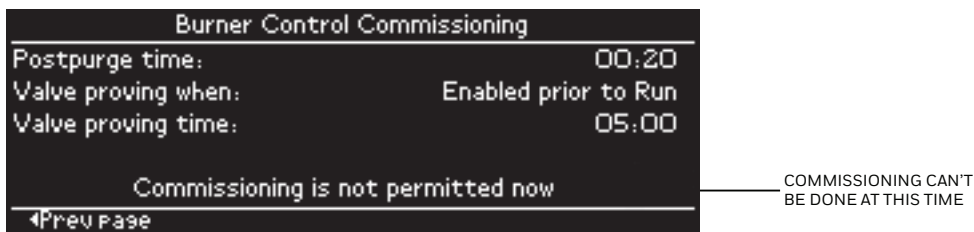
- Postpurge time
- Valve proving when option (when valve proving is executed)
- Valve proving time

Postpurge time specifies how long the burner should be purged after it leaves the “RUN” state. Valve proving (VP) is a feature that provides a systematic way of testing the valve seat integrity to assure the valves are indeed closed when the system is off-line or idle.



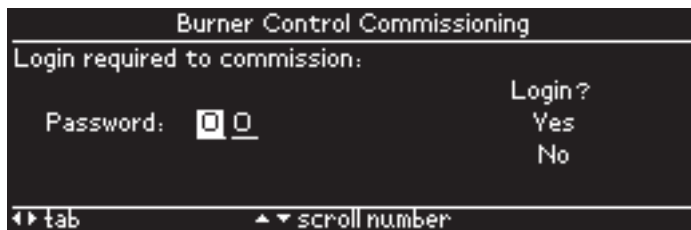
**Fig. 65. Enter commissioning**

If the burner control is not in a state that permits commissioning to proceed, the commissioning setup menu displays this fact, but does display the current parameter settings (see Fig. 66). Only action permitted in this case is to press the left arrow button to exit the menu and return back to the Display setup menu page.



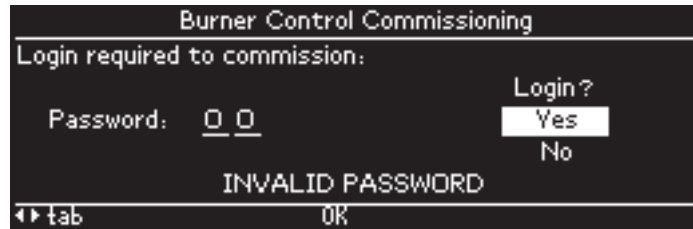
**Fig. 66. Commissioning not permitted**

When commissioning is allowed the user has the option to continue on with commissioning by selecting the “Yes” command or to exit the menu and not do commissioning with the “No” command. The right and left arrow buttons tab between the two options. Pressing the OK button executes the highlighted command. If “No” is selected, control returns back to the page that it originated from (Home or Display Menu). If “Yes” is selected, the user is requested to log into the burner control module with the commissioning password (see Fig. 67).



**Fig. 67. Commissioning login**

The commissioning password is “78”. The password is entered by scrolling the digits to “78” using the up and down arrow buttons when in the digit positions. The right and left arrow buttons navigate between the digits and the “Yes” and “No” commands. When the input focus is on the “Yes” and “No” commands the up and down arrow buttons tab between these two options. Pressing the OK button when the input focus is on “Yes” or “No” executes the command. A “Yes” command sends the password to the burner control module to begin commissioning. A successful login transitions to the first commission page. An unsuccessful login (wrong password) displays an “INVALID PASSWORD” message (see Fig. 68). If the “No” command is selected, commissioning is canceled and control returns to the previous page.



**Fig. 68. Invalid commissioning login**

If the login is unsuccessful, the user can retry the login by tabbing back to the password digits using the left or right arrow buttons and re-edit the password.

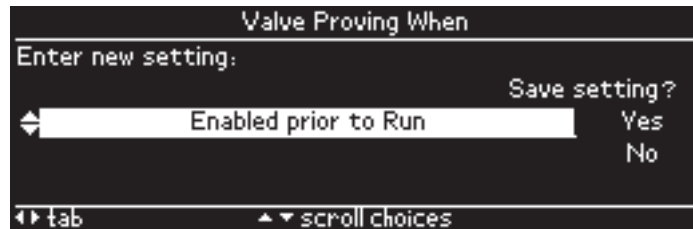
After a successful login the next commissioning page is automatically displayed (directed by the burner control module) to setup one of these parameters depending on the model:

- Valve Proving (VP) when option – see next figure
- Postpurge time – see Fig. 71

When valve proving is supported in the burner control module the feature is enabled by specifying when it should occur:

- Not enabled (feature is disabled)
- Enabled prior to RUN (occurs prior to ignition trials)
- Enabled after RUN (after burner is running and before internal safety relay dropout state)
- Enabled before and after RUN (occurs at both times prior to and after RUN)
- Enabled half before & after RUN (high pressure test occurs prior to RUN and low pressure test occurs after RUN)

The setting is selected by scrolling these choices using the up and down arrow buttons (see Fig. 69). The current parameter setting is displayed when the page is initially entered.



**Fig. 69. Commission valve proving when option**

The up and down arrow buttons are used to scroll through the choices on the edit line. The right and left arrow buttons are used to tab to the save commands, "Yes" and "No". When the input focus is on the save commands the up and down arrow buttons scroll between "Yes" and "No". When the choice is set to the desired value the "Yes" command is selected and the OK button is pressed to commit the change. If the user decides not to save the choice and exit commissioning, the "No" command is selected and the OK button is pressed.

When the setting is commissioned into the burner control module ("Yes" command is selected) the next page displayed is one of the following (directed by the burner control module):

- Valve Proving (VP) time commission (when VP is not disabled) – see next figure
- Postpurge time commission (when VP is disabled *and* postpurge time is supported in BC) – see Fig. 71
- Valve Proving (VP) when confirmation (when VP is disabled *and* postpurge time is not supported in BC) – see Fig. 72

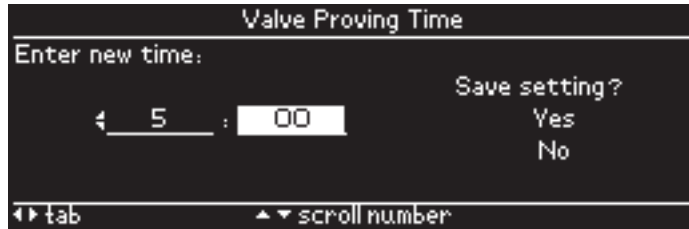
When valve proving is enabled in the burner control module the time duration of the test is configured (see Fig. 70).

NOTE: Tolerance on value proving timing value is  
+/- 10%.

The current setting is displayed allowing the user to change it to a new value. This time parameter has a range of 0-63 minutes with times that must be set in the following manner:

- 0-60 seconds in 1 second increments
- 1-10 minutes in 10 second increments
- 10-63 minutes in 1 minute increments

Because of these configuration constraints the minute and seconds digits increment/decrement in steps that force the time into these allowed settings.



**Fig. 70. Commission valve proving time**

The up and down arrow buttons are used to increment/decrement the minutes and seconds digits in the edit line. The right and left arrow buttons are used to tab to the save commands, “Yes” and “No”. When the input focus is on the save commands the up and down arrow buttons scroll between “Yes” and “No”. When the time is set to the desired value the “Yes” command is selected and the OK button is pressed to commit the change. If the user decides not to save the time and exit commissioning, the “No” command is selected and the OK button is pressed.

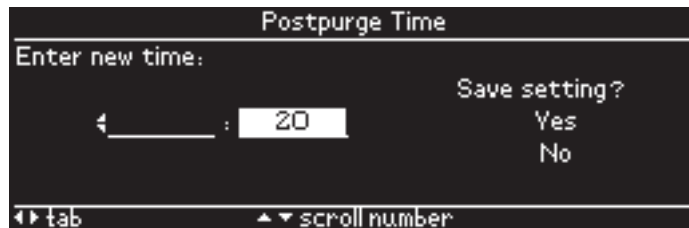
When the setting is commissioned into the burner control module (“Yes” command is selected) the next page displayed is one of the following (directed by the burner control module):

- Postpurge time commission (when postpurge time is supported in BC) – see Fig. 71
- Valve Proving (VP) when confirmation (when postpurge time is not supported in BC) – see Fig. 72

When postpurge time is supported in the burner control module it is configured in the following page (see next figure). Postpurge time is the time that the combustion fan remains energized after the burner is directed to stop (leave RUN). The current setting is displayed allowing the user to change it to a new value. This time parameter has a range of 0-63 minutes with times that must be set in the following manner (same as VP time):

- 0-60 seconds in 1 second increments
- 1-10 minutes in 10 second increments
- 10-63 minutes in 1 minute increments

Because of these configuration constraints the minute and seconds digits increment/decrement in steps that force the time into these allowed settings.



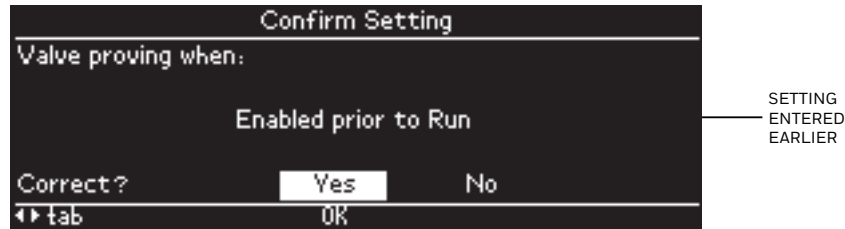
**Fig. 71. Commission Postpurge time**

The up and down arrow buttons are used to increment/decrement the minutes and seconds digits in the edit line. The right and left arrow buttons are used to tab to the save commands, “Yes” and “No”. When the input focus is on the save commands the up and down arrow buttons scroll between “Yes” and “No”. When the time is set to the desired value the “Yes” command is selected and the OK button is pressed to commit the change. If the user decides not to save the time and exit commissioning, the “No” command is selected and the OK button is pressed.

When the setting is commissioned into the burner control module (“Yes” command is selected) the next page displayed is one of the following (directed by the burner control module):

- Valve Proving (VP) when confirmation (when BC model supports valve proving) – see next figure
- Postpurge time confirmation (when BC model doesn’t support valve proving) – see Fig. 74

The user is asked to confirm the valve proving when option setting in the following page (see next figure). The option setting is displayed on the page, and the user confirms it with a “Yes” answer or declines it with a “No” answer.

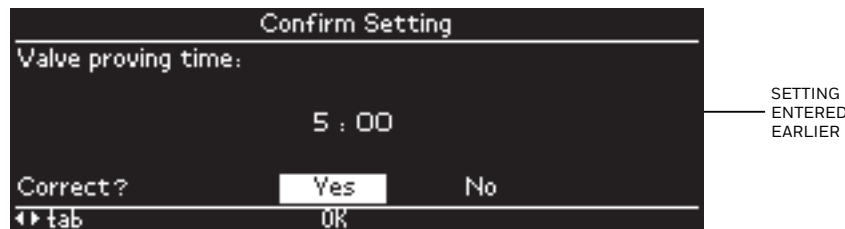


**Fig. 72. Confirm valve proving when option**

The right and left arrow buttons are used to tab between the “Yes” and “No” commands. When the decision is made the OK button is pressed to inform the burner control module. A “No” command stops the commissioning and control returns back to the commissioning menu. A “Yes” command causes the setting to be approved and one of the following pages to automatically display next (directed by the burner control module):

- Valve Proving (VP) time confirmation (VP when setting is not disabled) – see next figure
- Postpurge time confirmation (VP when setting is disabled *and* postpurge time has been configured) – see Fig. 74
- Burner commission reset (VP when setting is disabled *and* postpurge time was not configured) – see Fig. 75

The user is asked to confirm the valve proving time setting in the following page (see next figure). The time setting is displayed on the page, and the user confirms it with a “Yes” answer or declines it with a “No” answer.

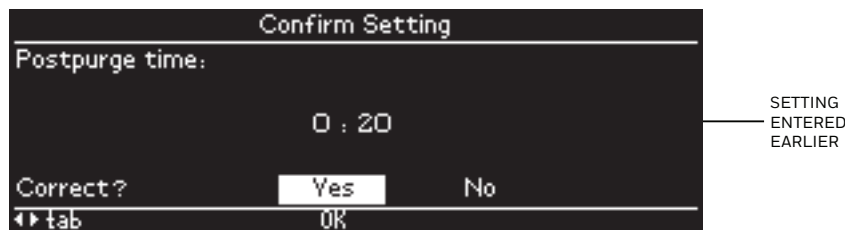


**Fig. 73. Confirm valve proving time**

The right and left arrow buttons are used to tab between the “Yes” and “No” commands. When the decision is made the OK button is pressed to inform the burner control module. A “No” command stops the commissioning and control returns back to the commissioning menu. A “Yes” command causes the setting to be approved and one of the following pages to automatically display next (directed by the burner control module):

- Postpurge time confirmation (postpurge time was configured earlier) – see next figure
- Burner commission reset (postpurge time was not configured earlier) – see Fig. 75

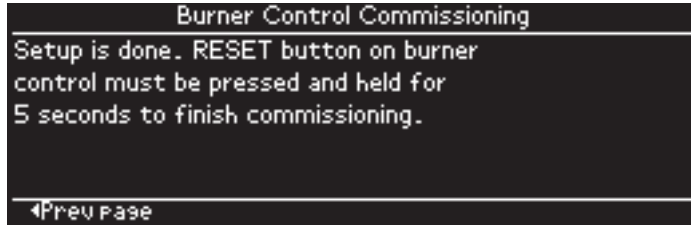
The user is asked to confirm the postpurge time setting in the following page (see next figure). The time setting is displayed on the page, and the user confirms it with a “Yes” answer or declines it with a “No” answer.



**Fig. 74. Confirm postpurge time**

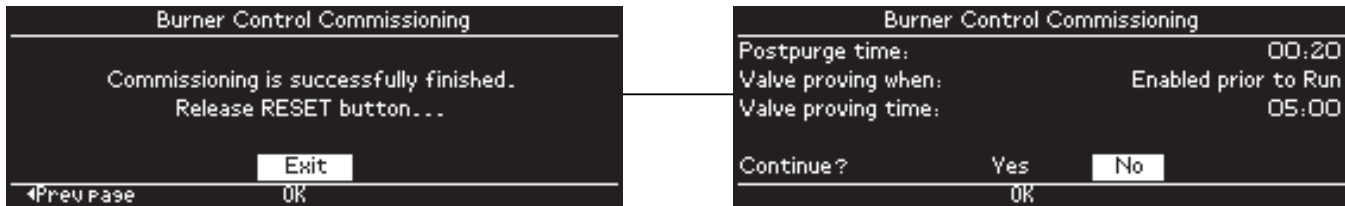
The right and left arrow buttons are used to tab between the “Yes” and “No” commands. When the decision is made the OK button is pressed to inform the burner control module. A “No” command stops the commissioning and control returns back to the commissioning menu. A “Yes” command causes the setting to be approved and the Burner commission reset page (see next figure) to automatically be displayed (directed by the burner control module).

The Burner commission reset page is displayed for the final step of the commissioning procedure. After all configuration and confirmations are done the RESET button on the burner control module must be pressed and held for 5 seconds. This page (see Fig. 75) automatically displays when the burner control module wants this reset action to be performed.



**Fig. 75. Commission RESET button**

After the RESET button has been held for 5 seconds the burner control module indicates that commissioning is successfully done (see Fig. 76). The left arrow or OK button can be pressed to exit commissioning and go back to the commissioning menu.



**Fig. 76. Commissioning successfully completed**

Each step of the commissioning procedure must be performed within 30 seconds after the page is displayed for the step. If the RESET button is released too early (less than 5 seconds) or the user doesn't respond to a procedure step within 30 seconds, the commissioning session is terminated by the burner control module and this failure is indicated on the page (see Fig. 77 for an example).



**Fig. 77. Failed commissioning step**

The user has the option to restart commissioning or not if the session fails to end completely. The "Yes" option is selected and the OK button pressed to redo commissioning by logging in again (see Fig. 67). The "No" option is selected and the OK button pressed to not redo commissioning which exits this page and returns back to the commissioning menu to show the current settings (see Fig. 64). The right and left arrow buttons are used to tab between the "Yes" and "No" options.

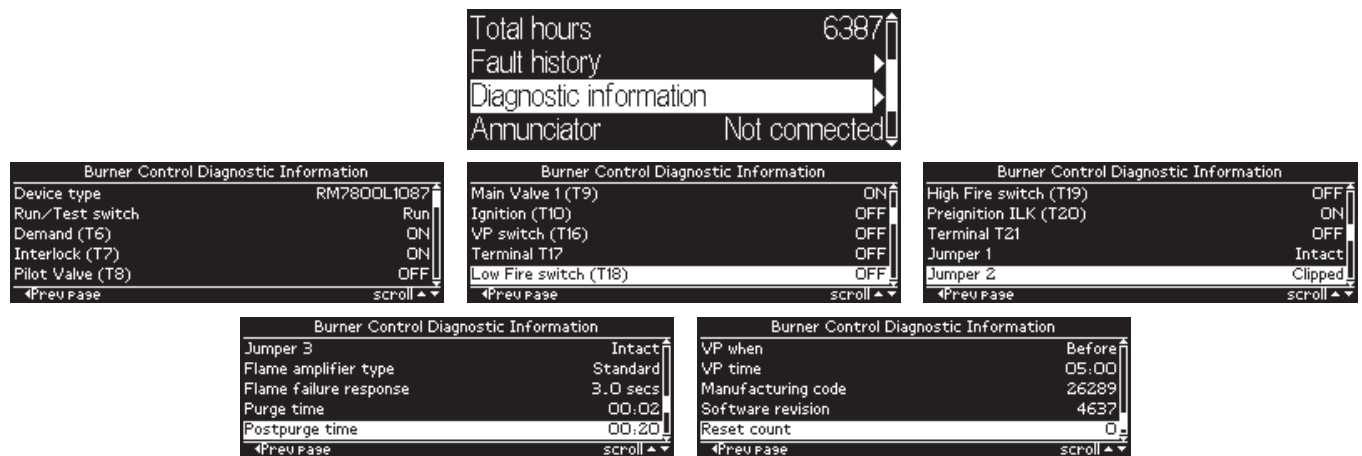
## APPENDIX C: DIAGNOSTICS

### Burner Control Diagnostics

Diagnostic information about the burner control module can be viewed on the display module (see Fig. 78). The information displayed is dependent on the burner control module. Only terminals and features that a burner control module includes are displayed. Possible information displayed are:

- Device (model) type
- Run/Test switch (if applicable) status – “Run” or “Test” mode
- Terminal T6-T21 (if applicable) status – “ON” or “OFF”
- Jumper 1-3 (if applicable) status – “Intact” or “Clipped”
- Flame amplifier type
- Flame failure response time (FFRT)
- Purge time (if applicable)
- Postpurge time (if applicable)
- Valve proving (VP) when option setting (if applicable)
- Valve proving (VP) time (if applicable)
- Manufacturing code
- Software revision
- Reset count (number of times the module has reset due to an internal fatal error)
- Reset reason code of most recent internal fatal error

Terminals are displayed with their model use, e.g., T6 may be used as a “Demand” or “Operating control” terminal.



**Fig. 78. Burner control diagnostics**

The up and down arrow buttons are used to scroll the status lines. The left arrow button is used to exit the page and return back to the Home page.

## Annunciator Diagnostics

Diagnostic information about the annunciator can be viewed on the display module when an annunciator is connected in the system (see Fig. 79). If an annunciator is not connected, this information is not accessible. The following information is displayed:

- Annunciator status
- T4-T22 terminal status – “ON” or “OFF”
- Fault (“first out”) code
- Software revision

The assigned terminal names display for the T4-T22 terminals.

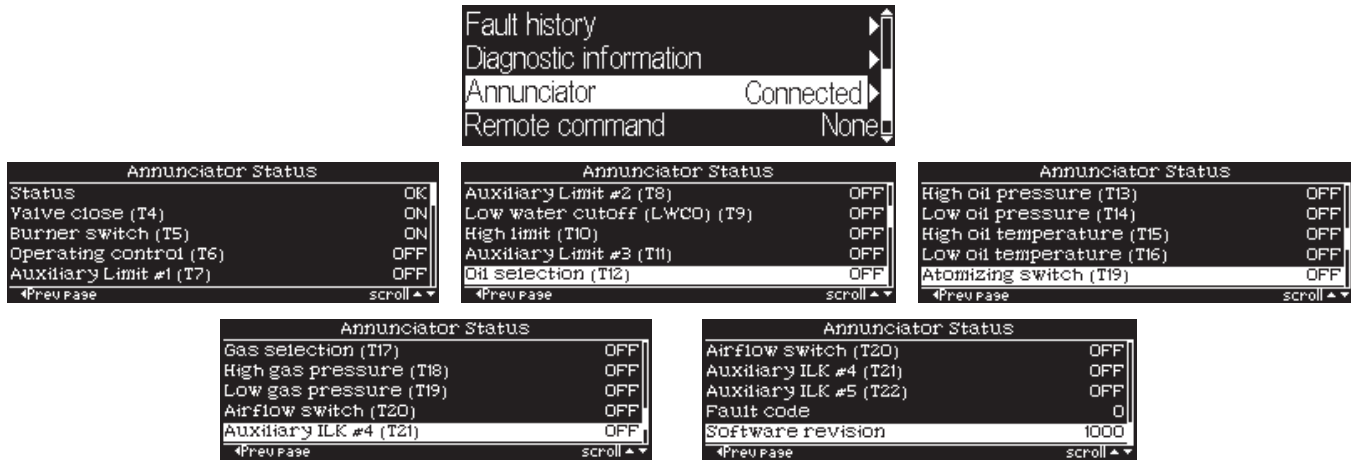


Fig. 79. Annunciator diagnostics

The up and down arrow buttons are used to scroll the status lines. The left arrow button is used to exit the page and return back to the Home page.

## Display Diagnostics

Diagnostic information about the display module can be viewed on a diagnostics page (see Fig. 80). The following information is displayed:

- Manufacturing code (when the display was built)
- Display software version
- Internal temperature (inside the display)
- Supply voltage to the display
- Backlight power (percentage of power driving the backlight)
- Backlight feedback (current feedback from backlight)
- Heater status (percentage of power driving the LCD heater)
- Number of received Modbus packets
- Number of transmitted Modbus packets

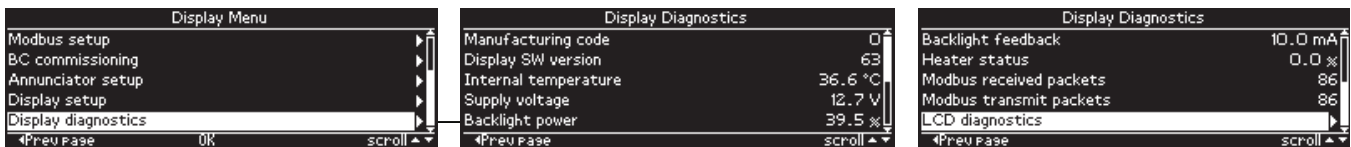
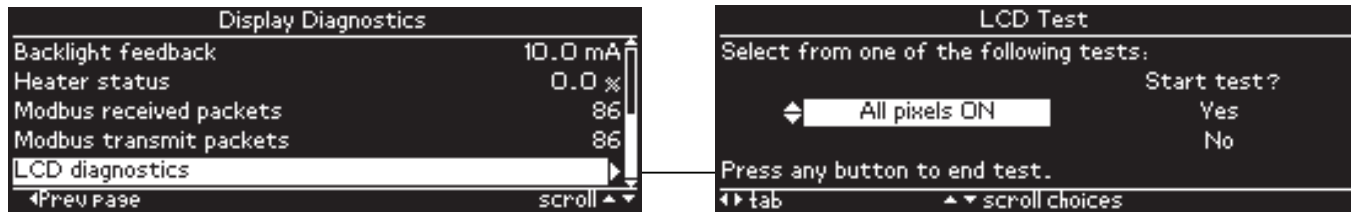


Fig. 80. Display diagnostics

More diagnostic lines exist than can fit on the main body of the page so the up and down arrow buttons are used to scroll among the lines. The left arrow button is used to exit this page and return back to the Display setup menu.

An additional selection line exists on the page to allow for LCD diagnostics to be initiated for checking the LCD hardware (see Fig. 81). The right arrow or OK button is used when this LCD diagnostics line is selected navigates to the LCD diagnostics page. One of the following tests can be conducted:

- All pixels ON (white display)
- All pixels OFF (black display)
- Fixed dots (every other pixel is on)



**Fig. 81. LCD diagnostics test**

The up and down arrow buttons are used to scroll through the different test selections. The right and left arrow buttons are used to tab to the “Start test” options, “Yes” and “No”. When the input focus is on the “Start test” options the up and down arrow buttons scroll between “Yes” and “No”. Pressing the OK button when the “Yes” option is selected begins the LCD test. The LCD test displays until the user presses any button to return back to the test selection page. Pressing the OK button when the “No” option is selected exits this page and returns back to the Display diagnostics page.

## APPENDIX D: ANNUNCIATOR TERMINAL MESSAGES

Annunciator terminals can be named to the messages listed in the following table. See “Annunciator Setup” on page 34 for the procedure that performs this name assignment. This name assignment is intended to match the annunciator terminal with the installation purpose of the terminal. The messages are categorized into the following groups:

- Standard terminal names (20 names)
- Common fixed names (17 names)
- Custom message names (20 names) - see “Annunciator Setup” on page 34

**Table 7. Annunciator Terminal Messages**

Message Group	Message Number	Text
Standard	4	Valve close
Standard	5	Burner switch
Standard	6	Operating control
Standard	7	Auxiliary Limit #1
Standard	8	Auxiliary Limit #2
Standard	9	Low water cutoff (LWCO)
Standard	10	High limit
Standard	11	Auxiliary Limit #3
Standard	12	Oil selection
Standard	13	High oil pressure
Standard	14	Low oil pressure
Standard	15	High oil temperature
Standard	16	Low oil temperature
Standard	17	Gas selection
Standard	18	High gas pressure
Standard	19 Gas	Low gas pressure
Standard	19 Oil	Atomizing switch
Standard	20	Airflow switch
Standard	21	Auxiliary ILK #4
Standard	22	Auxiliary ILK #5
Fixed	23	High water
Fixed	24	Low water
Fixed	25	High stack
Fixed	26	High blast
Fixed	27	Low pilot
Fixed	28	High pilot
Fixed	29	Combustion damper
Fixed	30	Stack damper PV
Fixed	31	FD fan ILK
Fixed	32	Recirculating fan
Fixed	33	Exhaust fan
Fixed	34	Combustion fan
Fixed	35	Oil pump
Fixed	36	Low FGR
Fixed	37	Low combustion AP
Fixed	38	High temperature
Fixed	39	Controlinks
Custom	45	Default 1*

**Table 7. Annunciator Terminal Messages**

<b>Message Group</b>	<b>Message Number</b>	<b>Text</b>
Custom	46	Default 2*
Custom	47	Default 3*
Custom	48	Default 4*
Custom	49	Default 5*
Custom	50	Default 6*
Custom	51	Default 7*
Custom	52	Default 8*
Custom	53	Default 9*
Custom	54	Default 10*
Custom	55	Default 11*
Custom	56	Default 12*
Custom	57	Default 13*
Custom	58	Default 14*
Custom	59	Default 15*
Custom	60	Default 16*
Custom	61	Default 17*
Custom	62	Default 18*
Custom	63	Default 19*
Custom	64	Default 20*

\* Custom message text is editable so this text can vary.

Custom annunciator and Call for Service messages can be edited using the characters listed in the following table.

**Table 8. Character Set**

<b>(space)</b>	<b>A-Z</b>	<b>a-z</b>	<b>0-9</b>	<b>.</b>	<b>,</b>	<b>-</b>	<b>/</b>	<b>:</b>	<b>"</b>	<b>?</b>
<	>	{	}	[	]	;		\		+
_	=	(	)	*	&	^	%	\$	#	@
!	?									

## APPENDIX E: MODBUS FUNCTION

See “Appendix A: Display Setup” on page 28 for Setup.

### OPERATION

The S7800 ModBus™ Data Feature enables terminal 1, 2 to Data + and Data -. Table 16 provides register mapping. It identifies the mapping of the 7800 SERIES parameters to ModBus™ registers.

### Function Codes

Supported function codes of Modbus Protocol Reference Guide (PI-MBUS-300 Rev. J) are 3, 4, 6, 16, and 17. Function codes 3 and 4 are treated the same by the S7800. Two registers should be read when the data format is a U32 value (4 bytes); if both registers are not read, then data for a part of the value is returned. U32 values are either in Big-endian or Little-endian format. The maximum number of addresses that can be queried is 127 (0x7F) for each query message.

Table 9 through 12 provide information on the function codes.

NOTE: All Query and Response cells below are 1 byte.

**Table 9. Query Message Format for Function Codes 3 and 4.**

Slave Address	Function Code	Starting Address High	Starting Address Low	Number of Addresses High	Number of Addresses Low	CRC	CRC
01	03 or 04	00	0A	00	01	A4	08

**Table 10. Response Message Format for Function Codes 3 and 4.**

Slave Address	Function Code	Byte Count	Data High	Data Low	CRC	CRC
01	03 or 04	02	00	22	38	5D

**Table 11. Query Message Format for Function Code 6 .**

Slave Address	Function Code	Starting Address High	Starting Address Low	Preset Data High	Preset Data Low	CRC	CRC
01	06	00	7F	00	04	B9	D1

**Table 12. Response Message Format for Function Code 6 (There is no response if the query was broadcast.)**

Slave Address	Function Code	Starting Address High	Starting Address Low	Preset Data High	Preset Data Low	CRC	CRC
01	06	00	7F	00	04	B9	D1

**Table 13. Query Message Format for Function Code 17.**

Slave Address	Function Code	CRC	CRC
03	11	C1	4C

NOTE: See Table 17 for function code 17 response format.

**Table 14. Exception Response Message Format.**

Slave Address	Function Code + 80h	Exception Code	CRC	CRC

**Table 15. Exception Codes.**

<b>Exception Code</b>	<b>Definition</b>	<b>Description</b>
01	Illegal Function	An illegal function as requested. Only 3, 4, 6 and 17 are supported.
02	Illegal Data Address	Too many bytes requested, address is out of range, register is read only, or the number of address requested is past the last register.
03	Illegal Data Value	The "Preset Data" from function code 6 is invalid/out of range.

## Device Address and Baud Rate

Assign each device in the system a unique address by setting the MODBUS ADDRESS (see page 28). Only RTU communications with 1 Start Bit, 8 Data Bits, 1 Stop Bit and no, odd, or even parity is supported.

NOTE: Assign a device address number from 01 to 255. 00 is not an acceptable address number and will not work.

NOTE: In Table 16: Line 1 and Line 2 refer to the two lines of text on the S7800 Keyboard Display Module. In Table 20: The String Code column references Table 21, String Codes. In Table 16: The Burner Control State Bits column references Table 19, Burner Control State Bits.

**Table 16. ModBus™ Register Assignments.**

Address (hex)	Register (dec)	Parameter Name	Read/Write	Format	Notes
0000	40001	Burner Control (BC) Fault Code	R	U16	See Table 22. Non-zero value = Lockout number.
0001	40002	BC Fault String Code	R	U16	See Table 21. Lockout text.
0002	40003	BC Sequence State	R	U16	See Table 20 (valid only if Fault code = 0).
0003	40004	BC State String Code (line 1)	R	U16	See Table 21. Simulates Line 1 of S7800.
0004	40005	BC State String Code (line 2)	R	U16	See Table 21. Simulates Line 2 of S7800.
0005	40006	BC Sequence time	R	U16	0-4095 Seconds.
0006	40007	BC Total cycles	R	U32	Max value is 0xFFFFFFFF.
0008	40009	BC Total hours	R	U32	Max value is 0xFFFFFFFF.
000A	40011	BC Flame 1 signal strength	R	U16	0 to 255 represents 0.0 to 25.5 volts. Not clipped to 5.0V like S7800.
000B	40012	BC Flame 2 signal strength	R	U16	0 to 4095. N/A for 7800 SERIES.
000C	40013	BC State Bits	R	U16	See Table 20.
000D	40014	S7830 First Out Code	R	U16	Not supported from S7800.
000E	40015	S7830 State Bits	R	U32	
0010-0019	40017-40026	BC Fault history record 1	R		Newest fault record. See Table 23.
001A-0023	40027-40036	BC Fault history record 2	R		Second newest fault record. See Table 23.
0024-002D	40037-40046	BC Fault history record 3	R		Third newest fault record. See Table 23.
002E-0037	40047-40056	BC Fault history record 4	R		Fourth newest fault record. See Table 23.
0038-0041	40057-40066	BC Fault history record 5	R		Fifth newest fault record. See Table 23.
0042-004B	40067-40076	BC Fault history record 6	R		Oldest fault record. See Table 23.
004C	40077	BC Flame Failure Response Time	R	U16	Tenths of Seconds.
004D	40078	BC Manufacturing code	R	U32	
004F	40080	BC Type Code	R	U16	See Table 18.
0050	40081	S7800M/BC Software version	R	U32	
0052	40083	EA Software version	R	U32	Does not apply.
0054	40085	BC Remote Command status.	R	U16	Bit 0: Autonomous. Bit 1: Remote commanded off. Bit 2: Remote commanded High fire. Bit 3: Remote commanded low fire. Bit 4: Remote reset has/will be sent to BC. <sup>a</sup> Bits 5-14: Unused. Bit 15: Copied after the most recent write to the burner control command (40128 bit 15).

**Table 16. ModBus™ Register Assignments. (Continued)**

Address (hex)	Register (dec)	Parameter Name	Read/Write	Format	Notes
0055	40086	BC Flame Amplifier type	R	U16	0 = Standard 1 = Unknown 2 = Amplicheck or missing amplifier 3 = Shutter
0056	40087	BC Purge Time	R	U16	Seconds
0057-0065	40088-40102	BC Diagnostics	R	U16	String codes indicating terminal/jumper state. See Table 21. There are up to 15 codes. Not all are used for some burner controls.
0066	40103	Post-Purge time	R	U16	Seconds
0067	40104	Valve Proving Mode	R	U16	0 = Valve Proving is not enabled 1 = Enabled before Run 2 = Enabled after Run 3 = Enabled before and after Run 4 = Enabled split half before and half after Run
0068	40105	Valve Proving option	R	U16	1 = Uncommissioned 2 = Commissioned
0069	40106	Valve Proving time	R	U16	Seconds
006A	40107	BC terminal state bits	R	U32	Bit 0 (LSB) to Bit 31 (MSB) represent terminals T0 to T31 of burner control: T0 = Run/Test switch T5 = Fan T6-T21 = terminal T24 = Alarm T25 = Modulate T26 = Reset T27 = Safety relay T28 = Flame ILK T29 = Main Valve 2
006C-007E	40109-40127	Unused			
007F	40128	BC Remote Command	R/W	U16	Only one bit in the LSByte must be set, with the exception of bit 15: Bit 0 =Revert to autonomous operation. Bit 1 = Don't fire, remain off. Bit 2 = Go to Hi Fire during Run. Bit 3 = Go to Lo Fire during Run. Bit 4 = Remote reset. <sup>a</sup> Bits 5-7 must be 0. Bits 8-14 are ignored. Bit 15: Copied to the control status register. The remote control status register can be used to verify operation of the command. Bits 1-3 must be refreshed at least every 120 seconds, but not more than once a second, for the burner control to remain in the commanded state.

**Table 16. ModBus™ Register Assignments. (Continued)**

Address (hex)	Register (dec)	Parameter Name	Read/Write	Format	Notes
01B7-01B8	40440-40441	Unused		U32	
01BA	40443	Device Data Ready		U16	Device data was properly received by S7800. <u>Bit(s)</u> 0 Device RM78XX 3 EC78XX 4-15 Unused
01BB	40444	S7800 Device Compatibility with Current Software Revision  S7800 Software Revision Compatibility with Legacy Software Revisions.		U16	Device is compatible with the S7810M version <u>Bit</u> 0 Device RM78XX 3 EC78XX 4-7 Unused  Used for indication of S7800 revision compatibility. <u>Bit(s)</u> 8 <u>Compatible with:</u> Series 2 9-15 Future
01BC	40445	Modbus U32 Endian	R/W	U16	Endian order for U32 registers: 0 = Big-Endian (MS U16 first) 1 = Little-Endian (LS U16 first)

NOTE: “Device Data Ready” and “S7800 Compatibility” bits can be used to quickly check device availability and compatibility then read/write registers of only these devices.

## Response Message Format for Function Code 17

This format is device specific and is only available for the 7800 SERIES burner control. See Table 13.

**Table 17. Response Message Format for function code 17 (11h), (26 bytes).**

	Slave Address	Function Code	Byte Count	Slave ID <sup>a</sup>	Run Indicator Status <sup>b</sup>	Device Description <sup>c</sup>	N/A	CRC	CRC
Byte	0	1	2	3	4	5-15	16-23	24	25

<sup>a</sup> Slave ID: Always 0x78 when using RM78xx or EC78xx Relay Modules(1 byte) (byte 3).

<sup>b</sup> Run Indicator Status: Always FF=ON (one byte) (byte 4).

<sup>c</sup> Device Description: 16 character ASCII OS number for the Burner Control (11 bytes) (bytes 1-11).

## Burner Control Type Codes

The burner control type code indicates the exact model number of the burner control. See Table 18.

**Table 18. Burner Control Type Codes.**

<b>CODE</b>	<b>DEVICE DESCRIPTION</b>
0	(undefined)
100	RM7800E
101	RM7800G
102	RM7800L
103	RM7800M
104	RM7838A
105	RM7838B
106	RM7840E
107	RM7840G
108	RM7840L
109	RM7840M
110	RM7885A
111	RM7888A
112	RM7890A
113	RM7895A
114	RM7895B
115	RM7823A
116	RM7824A
117	RM7830A
118	RM8738C
119	RM7845A
120	RM7850A
121	RM7865A
122	RM7865B
123	RM7865C
124	RM7890B
125	RM7890C
126	RM7890D
127	RM7895C
128	RM7895D
129	RM7895E
130	RM7895F
131	RM7896A
132	RM7896B
133	RM7896C
134	RM7896D
135	RM7897A
136	RM7897C
137	RM7898A
138	R7140G
139	R7140L
140	R7140M
199	RM78xx
200	EC7810A
201	EC7820A
202	EC7830A

**Table 18. Burner Control Type Codes.**

CODE	DEVICE DESCRIPTION
203	EC7850A
204	EC7885A
205	EC7890A
206	EC7895A
207	EC7895C
208	EC7823A
209	EC7840L
210	EC7865
299	EC78xx

## 7800 SERIES Burner Control State Bits

The burner control sequence state is translated into State Bit Register as shown in Table 20.

**Table 19. Burner Control State Bits.**

BIT	Description	BC State Bits Register
0	Initiate	0000 0000 0000 0001
1	Standby	0000 0000 0000 0010
2	Purge	0000 0000 0000 0100
3	Pilot Ignition	0000 0000 0000 1000
4	Main Ignition	0000 0000 0001 0000
5	Run	0000 0000 0010 0000
6	Postpurge	0000 0000 0100 0000
7	Pre-Ignition	0000 0000 1000 0000
8	Valve Proving	0000 0001 0000 0000
13	Alarm	1010 0000 xxxx xxxx NOTE: Lockout bit is also set.
14	Hold	0100 0000 xxxx xxxx One other bit may be on.
15	Lockout	1010 0000 0000 0000 NOTE: Alarm bit is also set.

## 7800 SERIES Sequence State Codes

Sequence state codes are provided by the Burner Control. Each code is translated into two string codes for displaying an associated message in two lines. Each code is also translated into burner control state bits which may be used to generate and control system diagrams on an operator interface. The codes can also be retrieved from registers 40004, 40005, and 40013.

The Sequence State Codes shown in Table 20 are valid only if the Fault Code has a value of zero. If the Fault Code is non-zero, the sequence state field contains the sequence state code when the lockout occurred.

**Table 20. 7800 SERIES Sequence State Codes and Associated register code values.**

Register 40003	7800 SERIES Sequence State	String Code		Uses mm:ss	Burner Control State Bits
		Line 1	Line 2		
Fault code not zero	LOCKOUT	52	Table 22		8000h
0	UNUSED HISTORY	0	0		0000h
1	INITIATE	48	0	✓	0001h
2	INITIATE HOLD: AC FREQUENCY/NOI SE	49	8		4001h
3	INITIATE HOLD: AC LINE DROPOUT	49	9		4001h
4	INITIATE HOLD: AC FREQUENCY	49	7		4001h
5	INITIATE HOLD: LOW LINE VOLTAGE	49	60		4001h
6	STANDBY	103	0		0002h
7	STANDBY HOLD: REM REMOTE CONTROL	104	94		4002h
8	STANDBY HOLD: START SWITCH	104	106		4002h
9	STANDBY HOLD: F/G FLAME DETECTED	104	35		4002h
10	STANDBY HOLD: T20 PRE-IGNITION	104	86		4002h
11	STANDBY HOLD: T7 RUNNING INTERLOCK	104	101		4002h
12	STANDBY HOLD: T7 LOCKOUT INTERLOCK	104	54		4002h
13	STANDBY HOLD: AIRFLOW SWITCH	104	13		4002h
14	PURGE HOLD: T19 HIGH FIRE SWITCH	93	40		4004h
15	PURGE DELAY: T19 HIGH FIRE JUMPRD	89	39		4004h
16	PURGE HOLD: TEST RUN/TEST SWITCH	93	98		4004h
17	PURGE DELAY: T18 LOW FIRE JUMPRD	89	56		4004h
18	PURGE HOLD: F/G FLAME DETECTED	93	35		4004h
19	PURGE	87	0	✓	0004h

**Table 20. 7800 SERIES Sequence State Codes and Associated register code values. (Continued)**

Register 40003	7800 SERIES Sequence State	String Code		Uses mm:ss	Burner Control State Bits
		Line 1	Line 2		
20	PURGE HOLD: T18 LOW FIRE SWITCH	93	58		4004h
21	PuRGE HOLD: T7 Running Interlock	93	101		4004h
22	PURGE HOLD: LOCKOUT INTERLOCK	93	54		4004h
23	PURGE HOLD: AIRFLOW SWITCH	93	13		4004h
24	PURGE HOLD: START SWITCH	93	106		4004h
25	PILOT IGN	78	0	✓	0008h
26	PILOT HOLD: TEST RUN/TEST SWITCH	77	98		4008h
27	PILOT HOLD: START SWITCH	77	106		4008h
28	MAIN IGN	66	0	✓	0010h
29	MAIN IG HOLD: MANUAL-OPEN SWITCH	67	72		4010h
30	RUN	95	0		0020h
31	RUN PV HOLD: LOW FIRE SWITCH	96	58		4020h
32	PVHOLD IGN	77	46	✓	4008h
33	PV HOLD: PV HOLD SWITCH	77	45		4008h
34	RUN/LOWFIRE: TEST RUN/TEST SWITCH	97	98		4020h
35	POSTPURGE	83	0	✓	0040h
36	STATE UNKNOWN	31	0		6000h
37	RESET/ALARM TEST	111	0		6000h
38	SAFETY START	102	105		4002h
39	SAFETY1-1	102	2	✓	0008h
40	SAFETY1-2	102	3	✓	0008h
41	SAFETY1-3	102	4	✓	0008h
42	SAFETY1-4	102	5	✓	0008h
43	SAFETY1-5	102	6	✓	0008h
44	Blank	0	0		A000h
45	PRE-IGNITION	84	0	✓	0080h
46	SAFETY 1	102	1	✓	0008h
47	PILOT STAB.	79	0		0008h
48	MAIN TRIAL	68	0	✓	0010h
49	MAIN TRIAL	68	0		0010h

**Table 20. 7800 SERIES Sequence State Codes and Associated register code values. (Continued)**

Register 40003	7800 SERIES Sequence State	String Code		Uses mm:ss	Burner Control State Bits
		Line 1	Line 2		
50	STANDBY HOLD: RUN/TEST SWITCH	104	98		4002h
51	STATE 51	31	0		A000h
52	STATE 52	31	0		A000h
53	SAFETY RUN/TEST SWITCH	102	98		4008h
54	STATE 54	31	0		A000h
55	STANDBY HOLD: PURGE FAN SWITCH	104	92		4002h
56	STATE 56	31	0		A000h
57	PURGE HOLD: PURGE FAN SWITCH	93	92		4004h
58	STANDBY HOLD FLAME DETECTED	104	35		4002h
59	STANDBY HOLD COMB. PRESSURE	104	26		4002h
60	VP START	210	0	✓	4100h
61	VP MV2 ON	211	0	✓	4100h
62	VP LOW DLY	212	0	✓	4100h
63	VP LOW TST	213	0	✓	4100h
64	VP MV1 ON	214	0	✓	4100h
65	VP HIGH DLY	215	0	✓	4100h
66	VP HIGH TST	216	0	✓	4100h
67	INITIATE HOLD: AC AC PHASE ERROR	49	10		4001h
68	STANDBY HOLD: PRE-IGNITION ILK	104	85		4002h
69	SETUP NEEDED	217	0		A000h
70	STATE 70	31	0		A000h
71	BURNER OFF: T6 BURNER SWITCH	22	23		4002h
72	STANDBY HOLD: (EA) HOLD MSG	184	30		4002h
73	STANDBY HOLD: (EA) CIRCUIT FAULT	184	25		4002h
74	STANDBY HOLD (EA)	184	Varie s		4002h
75	PURGE HOLD (EA)	185	Varie s		4004h
76	UNUSED	0			
77	UNUSED	0			0h
78	UNUSED	0			0h

**Table 20. 7800 SERIES Sequence State Codes and Associated register code values. (Continued)**

Register 40003	7800 SERIES Sequence State	String Code		Uses mm:ss	Burner Control State Bits
		Line 1	Line 2		
79	UNUSED	0			0h
80	UNUSED	0			0h
81	STANDBY HOLD (EA): VALVE CLOSURE	184	109		4002h
82	STANDBY HOLD (EA) OTHER PII	184	75		4002h

## 7800 SERIES String Codes

Table 23 contains a listing of all string codes provided by the S7800 Keyboard Display Module or similar device.

**Table 21. 7800 SERIES String codes.**

String Code	String
0	(blank)
1	1
2	1-1
3	1-2
4	1-3
5	1-4
6	1-5
7	AC FREQUENCY
8	AC Frequency/Noise
9	AC LINE DROPOUT
10	AC PHASE
11	ACCESSORY FAULT
12	AIRFLOW SW. ON
13	AIRFLOW SWITCH
14	ATOMIZING SW
15	AUX INTERLOCK #4
16	AUX INTERLOCK #5
17	AUX LIMIT #1
18	AUX LIMIT #2
19	AUX LIMIT #3
20	BLOCK INTAKE
21	BOTH FUELS SELECT
22	BURNER OFF
23	BURNER SWITCH
24	CALL SERVICE
25	CIRCUIT FAULT
26	COMB. PRESSURE
27	CONTROL ON
28	DELAYED MV ON
29	DEVICE SPECIFIC
30	EA HOLD MESSAGES

**Table 21. 7800 SERIES String codes. (Continued)**

String Code	String
31	UNKNOWN STATE
32	FLAME AMP TYPE
33	FLAME AMP/SHUTR
34	FLAME AMPLIFIER
35	FLAME DETECTED
36	FLAME TOO STRONG
37	FLAME-OUT TIMER
38	FUEL SELECT OFF
39	HIGH FIRE JUMPERED
40	HIGH FIRE SWITCH
41	HIGH GAS PRESSURE
42	HIGH LIMIT
43	HIGH OIL PRESSURE
44	HIGH OIL TEMP
45	HOLD SWITCH
46	IGNITION
47	IGNITION ON
48	INITIATE
49	INITIATE HOLD
50	JUMPERS CHANGED
51	JUMPERS WRONG
52	LOCKOUT
53	LOCKOUT ILK ON
54	LOCKOUT INTERLOCK
55	LOCKOUT SWITCH
56	LOW FIRE JUMPERED
57	LOW FIRE SW OFF
58	LOW FIRE SWITCH
59	LOW GAS PRESSURE
60	LOW LINE VOLTAGE
61	LOW OIL PRESSURE
62	LOW OIL TEMP
63	LWCO
64	MAIN FLAME FAIL
65	MAIN FLAME IGN.
66	MAIN IGN
67	MAIN IGN HOLD
68	MAIN TRIAL
69	MAIN VALVE ON
70	MAN-OPEN SW. OFF
71	MAN-OPEN SW. ON
72	MAN-OPEN SW.
73	NO PURGE CARD
74	OTHER INTERLOCKS
75	OTHER PREIGN ILK
76	PILOT FLAME FAIL

Table 21. 7800 SERIES String codes. (Continued)

String Code	String
77	PILOT HOLD
78	PILOT IGN
79	PILOT STABILIZE
80	PILOT VALVE 1 ON
81	PILOT VALVE 2 ON
82	POOR FLAME SENSOR
83	POSTPURGE
84	PRE-IGNITION
85	PRE-IGNITION ILK
86	PRE-IGNITION
87	PURGE
88	PURGE CARD ERROR
89	PURGE DELAY
90	PURGE FAN SW OFF
91	PURGE FAN SW ON
92	PURGE FAN SWITCH
93	PURGE HOLD
94	REMOTE CONTROL
95	RUN
96	RUN HOLD
97	RUN/LOWFIRE
98	RUn/TEST SWITCH
99	RUNNING ILK
100	RUNNING ILK ON
101	RUNNING INTERLOCK
102	SAFETY
103	STANDBY
104	STANDBY HOLD
105	START
106	START SWITCH
107	START SWITCH ON
108	TEST STATE
109	VALVE CLOSURE
110	ALL SWITCHES ON
111	RESET/ALARM TEST
112	Run/Test Switch RUN
113	Run/Test Switch TEST
114	Operator Control T6 = 0
115	Operator Control T6 = 1
116	Interlock T7 = 0
117	Interlock T7 = 1
118	Airflow Interlock T7 = 0
119	Airflow Interlock T7 = 1
120	Block Intake T7 = 0
121	Block Intake T7 = 1
122	Valve T8 = 0

Table 21. 7800 SERIES String codes. (Continued)

String Code	String
123	Valve T8 = 1
124	Intrptd PV T8 = 0
125	Intrptd PV T8 = 1
126	Main Valve T9 = 0
127	Main Valve T9 = 1
128	Ignition T10 = 0
129	Ignition T10 = 1
130	PV Hold T16 = 0
131	PV Hold T16 = 1
132	Input A T16 = 0
133	Input A T16 = 1
134	ManOpenSw T17 = 0
135	ManOpenSw T17 = 1
136	Input B T17 = 0
137	Input B T17 = 1
138	Prelgn ILK T17 = 0
139	Prelgn ILK T17 = 1
140	LowFire Sw T18 = 0
141	LowFire Sw T18 = 1
142	Purge Fan T18 = 0
143	Purge Fan T18 = 1
144	HighFire Sw T19 = 0
145	HighFire Sw T19 = 1
146	Prelgn ILK T20 = 0
147	Prelgn ILK T20 = 1
148	Lockout Inp T20 = 0
149	Lockout Inp T20 = 1
150	Comb Press T20 = 0
151	Comb Press T20 = 1
152	Valv/Start T21 = 0
153	Valv/Start T21 = 1
154	Intmitt PV T21 = 0
155	Intmitt PV T21 = 1
156	Terminal T6 = 0
157	Terminal T6 = 1
158	Terminal T7 = 0
159	Terminal T7 = 1
160	Terminal T8 = 0
161	Terminal T8 = 1
162	Terminal T9 = 0
163	Terminal T9 = 1
164	Terminal T10 = 0
165	Terminal T10 = 1
166	Terminal T16 = 0
167	Terminal T16 = 1
168	Terminal T17 = 0

**Table 21. 7800 SERIES String codes. (Continued)**

String Code	String
169	Terminal T17 = 1
170	Terminal T18 = 0
171	Terminal T18 = 1
172	Terminal T19 = 0
173	Terminal T19 = 1
174	Terminal T20 = 0
175	Terminal T20 = 1
176	Terminal T21 = 0
177	Terminal T21 = 1
178	Jumper 1 Intact
179	Jumper 1 Clipped
180	Jumper 2 Intact
181	Jumper 2 Clipped
182	Jumper 3 Intact
183	Jumper 3 Clipped)
NOTE: The values that follow are generated when the fault code is zero and the Expanded Annunciator code indicates that one or more switches are open. The Line 2 string code will indicate which switch is open.	
184	STANDBY HOLD (EA)
185	PURGE HOLD (EA)
186	PILOT HOLD (EA)
187	MAIN IG HOLD (EA)
188	RUN HOLD (EA)
189	POSTPURGE HOLD (EA)
190	PRE-IGNITION HOLD (EA)
191	-SKIPPED-
192	DEMAND T6 = 0
193	DEMAND T6 = 1
194	PILOT VALVE T8 = 0
195	PILOT VALVE T8 = 1
196	INTERMIT PV T8 = 0
197	INTERMIT PV T8 = 1
198	MAIN VALVE1 T9 = 0
199	MAIN VALVE1 T9 = 1
200	VP SWITCH T16 = 0
201	VP SWITCH T16 = 1
202	MAIN VALVE2 T17 = 0
203	MAIN VALVE2 T17 = 1
204	INTRUPTD PV T21 = 0
205	INTRUPTD PV T21 = 1
206	DELAYED MV T21 = 0
207	DELAYED MV T21 = 1
208	START SW T21 = 0
209	START SW T21 = 1
210	VP START

**Table 21. 7800 SERIES String codes. (Continued)**

String Code	String
211	VP MV2 ON
212	VP LOW DLY
213	VP LOW TST
214	VP MV1 ON
215	VP HIGH DLY
216	VP HIGH TST
217	VP SETUP NEEDED
218	MAIN VALVE 1 OFF
219	MAIN VALVE 2 OFF
220	MAIN VALVE 1 ON
221	MAIN VALVE 2 ON
222	VPS OFF
223	VPS ON

### 7800 SERIES Fault Codes

Table 22 is a complete list of fault codes that may appear in the fault code register. The Fault String Code register will contain the corresponding String code identified in the table.

**Table 22. 7800 SERIES Fault Codes.**

Fault Code (Reg 40001)	Fault Message (NOTE: FAULT n: is not in the Fault and Strings Code)	Fault String Code (Table 22)
0	Blank (no fault)	0
1	FAULT 1: NO PURGE CARD	73
2	FAULT 2: AC FREQUENY/NOISE	8
3	FAULT 3: AC LINE DROPOUT	9
4	FAULT 4: AC FREQUENCY	7
5	FAULT 5: LOW LINE VOLTAGE	60
6	FAULT 6: PURGE CARD ERROR	88
7	FAULT 7: FLAME AMPLIFIER	34
8	FAULT 8: FLAME AMP/SHUTR	33
9	FAULT 9: FLAME DETECTED	35
10	FAULT 10: PRE-IGNITION ILK	85
11	FAULT 11: RUNNING ILK ON	100
12	FAULT 12: LOCKOUT ILK ON	53
13	FAULT 13: AIRFLOW SW. ON	12
14	FAULT 14: HIGH FIRE SWITCH	40
15	FAULT 15: FLAME DETECTED	35
16	FAULT 16: FLAME-OUT TIMER	37
17	FAULT 17: MAIN FLAME FAIL	64
18	FAULT 18: FLAME DETECTED	35
19	FAULT 19: MAIN FLAME IGN.	65
20	FAULT 20: LOW FIRE SW OFF	57
21	FAULT 21: RUNNING ILK	99

Table 22. 7800 SERIES Fault Codes. (Continued)

Fault Code (Reg 40001)	Fault Message (NOTE: FAULT n: is not in the Fault and Strings Code)	Fault String Code (Table 22)
22	FAULT 22: LOCKOUT ILK	54
23	FAULT 23: AIRFLOW SWITCH	13
24	FAULT 24: CALL SERVICE	24
25	FAULT 25: CALL SERVICE	24
26	FAULT 26: MAN-OPEN SW. OFF	70
27	FAULT 27: START SWITCH ON	107
28	FAULT 28: PILOT FLAME FAIL	76
29	FAULT 29: LOCKOUT ILK	54
30	FAULT 30: RUNNING ILK	101
31	FAULT 31: LOW FIRE SW OFF	57
32	FAULT 32: AIRFLOW SWITCH	13
33	FAULT 33: PRE-IGNITION ILK	85
34	FAULT 34: CONTROL ON	27
35	FAULT 35: CALL SERVICE	24
36	FAULT 36: CALL SERVICE	24
37	FAULT 37: CALL SERVICE	24
38	FAULT 38: CALL SERVICE	24
39	FAULT 39: CALL SERVICE	24
40	FAULT 40: CALL SERVICE	24
41	FAULT 41: MAIN VALVE ON	69
42	FAULT 42: PILOT VALVE 1 ON	80
43	FAULT 43: IGNITION ON	47
44	FAULT 44: PILOT VALVE 2 ON	81
45	FAULT 45: LOW FIRE SW OFF	57
46	FAULT 46: FLAME AMP TYPE	32
47	FAULT 47: JUMPERS CHANGED	50
48	FAULT 48: DELAYED MV ON	28
49	FAULT 49: MAN-OPEN SW. ON	71
50	FAULT 50: JUMPERS WRONG	51
51	FAULT 51: FLAME TOO STRONG	36
52	FAULT 52: CALL SERVICE	24
53	FAULT 53: LOCKOUT SWITCH	55
54	FAULT 54: COMB. PRESSURE	26
55	FAULT 55: PURGE FAN SW ON	91
56	FAULT 56: BLOCK INTAKE	20
57	FAULT 57: PURGE FAN SW OFF	90
58	FAULT 58: COMB. PRESS/FLAME	26
59	FAULT 59: CALL SERVICE	24
60	FAULT 60: CALL SERVICE	24
61	FAULT 61: MV1 OFF	218
62	FAULT 62: MV2 OFF	219
63	FAULT 63: MV1 ON	220
64	FAULT 64: MV2 ON	221

Table 22. 7800 SERIES Fault Codes. (Continued)

Fault Code (Reg 40001)	Fault Message (NOTE: FAULT n: is not in the Fault and Strings Code)	Fault String Code (Table 22)
65	FAULT 65: VPS OFF	222
66	FAULT 66: VPS ON	223
67	FAULT 67: AC PHASE	10
68	FAULT 68: PRE-IGNITION ILK	85
69	FAULT 69: CALL SERVICE	24
70	FAULT 70: CALL SERVICE	24
71-75	FAULT 71-75: DEVICE SPECIFIC	29
76-93	FAULT 76-93: ACCESSORY FAULT	11
94-127	FAULT 94-127: CALL SERVICE	24
128	FAULT 128: POOR FLAME SENSOR	82
129-141	FAULT 129-141: CALL SERVICE	24
142	FAULT 68z: OTHER PREIGN ILK <sup>EA</sup>	75
143	FAULT 68y: VALVE CLOSURE <sup>EA</sup>	109
144	FAULT 33z: OTHER PREIGN ILK <sup>EA</sup>	75
145	FAULT 33y: VALVE CLOSURE <sup>EA</sup>	109
146	FAULT 32s: OTHER INTERLOCKS <sup>EA</sup>	74
147	FAULT 32r: AUX INTERLOCK #5 <sup>EA</sup>	16
148	FAULT 32q: AUX INTERLOCK #4 <sup>EA</sup>	15
149	FAULT 32p: AIRFLOW SWITCH <sup>EA</sup>	13
150	FAULT 32o: LOW GAS PRESSURE <sup>EA</sup>	59
151	FAULT 32n: HIGH GAS PRESSURE <sup>EA</sup>	41
152	FAULT 32m: ATOMIZING SW <sup>EA</sup>	14
153	FAULT 32k: LOW OIL TEMP <sup>EA</sup>	62
154	FAULT 32j: HIGH OIL TEMP <sup>EA</sup>	44
155	FAULT 32i: LOW OIL PRESSURE <sup>EA</sup>	61
156	FAULT 32h: HIGH OIL PRESSURE <sup>EA</sup>	43
157	FAULT 32g: BOTH FUELS SELECT <sup>EA</sup>	21
158	FAULT 32f: FUEL SELECT OFF <sup>EA</sup>	38
159	FAULT 32e: AUX LIMIT #3 <sup>EA</sup>	19
160	FAULT 32d: HIGH LIMIT <sup>EA</sup>	42
161	FAULT 32c: LWCO <sup>EA</sup>	63
162	FAULT 32b: AUX LIMIT #2 <sup>EA</sup>	18
163	FAULT 32a: AUX LIMIT #1 <sup>EA</sup>	17
164	FAULT 30s: OTHER INTERLOCKS <sup>EA</sup>	74
165	FAULT 30r: AUX INTERLOCK #5 <sup>EA</sup>	16
166	FAULT 30q: AUX INTERLOCK #4 <sup>EA</sup>	15
167	FAULT 30p: AIRFLOW SWITCH <sup>EA</sup>	13
168	FAULT 30o: LOW GAS PRESSURE <sup>EA</sup>	59

Table 22. 7800 SERIES Fault Codes. (Continued)

Fault Code (Reg 40001)	Fault Message (NOTE: FAULT n: is not in the Fault and Strings Code)	Fault String Code (Table 22)
169	FAULT 30n: HIGH GAS PRESSURE <sup>EA</sup>	41
170	FAULT 30m: ATOMIZING SW <sup>EA</sup>	14
171	FAULT 30k: LOW OIL TEMP <sup>EA</sup>	62
172	FAULT 30j: HIGH OIL TEMP <sup>EA</sup>	44
173	FAULT 30i: LOW OIL PRESSURE <sup>EA</sup>	61
174	FAULT 30h: HIGH OIL PRESSURE <sup>EA</sup>	43
175	FAULT 30g: BOTH FUELS SELECT <sup>EA</sup>	21
176	FAULT 30f: FUEL SELECT OFF <sup>EA</sup>	38
177	FAULT 30e: AUX LIMIT #3 <sup>EA</sup>	19
178	FAULT 30d: HIGH LIMIT <sup>EA</sup>	42
179	FAULT 30c: LWCO <sup>EA</sup>	63
180	FAULT 30b: AUX LIMIT #2 <sup>EA</sup>	18
181	FAULT 30a: AUX LIMIT #1 <sup>EA</sup>	17
182	FAULT 29s: OTHER INTERLOCKS <sup>EA</sup>	74
183	FAULT 29r: AUX INTERLOCK #5 <sup>EA</sup>	16
184	FAULT 29q: AUX INTERLOCK #4 <sup>EA</sup>	15
185	FAULT 29p: AIRFLOW SWITCH <sup>EA</sup>	13
186	FAULT 29o: LOW GAS PRESSURE <sup>EA</sup>	59
187	FAULT 29n: HIGH GAS PRESSURE <sup>EA</sup>	41
188	FAULT 29m: ATOMIZING SW <sup>EA</sup>	14
189	FAULT 29k: LOW OIL TEMP <sup>EA</sup>	62
190	FAULT 29j: HIGH OIL TEMP <sup>EA</sup>	44
191	FAULT 29i: LOW OIL PRESSURE <sup>EA</sup>	61
192	FAULT 29h: HIGH OIL PRESSURE <sup>EA</sup>	43
193	FAULT 29g: BOTH FUELS SELECT <sup>EA</sup>	21
194	FAULT 29f: FUEL SELECT OFF <sup>EA</sup>	38
195	FAULT 29e: AUX LIMIT #3 <sup>EA</sup>	19
196	FAULT 29d: HIGH LIMIT <sup>EA</sup>	42
197	FAULT 29c: LWCO <sup>EA</sup>	63
198	FAULT 29b: AUX LIMIT #2 <sup>EA</sup>	18
199	FAULT 29a: AUX LIMIT #1 <sup>EA</sup>	17
200	FAULT 23s: OTHER INTERLOCKS <sup>EA</sup>	74
201	FAULT 23r: AUX INTERLOCK #5 <sup>EA</sup>	16
202	FAULT 23q: AUX INTERLOCK #4 <sup>EA</sup>	15
203	FAULT 23p: AIRFLOW SWITCH <sup>EA</sup>	13
204	FAULT 23o: LOW GAS PRESSURE <sup>EA</sup>	59
205	FAULT 23n: HIGH GAS PRESSURE <sup>EA</sup>	41

Table 22. 7800 SERIES Fault Codes. (Continued)

Fault Code (Reg 40001)	Fault Message (NOTE: FAULT n: is not in the Fault and Strings Code)	Fault String Code (Table 22)
206	FAULT 23m: ATOMIZING SW <sup>EA</sup>	14
207	FAULT 23k: LOW OIL TEMP <sup>EA</sup>	62
208	FAULT 23j: HIGH OIL TEMP <sup>EA</sup>	44
209	FAULT 23i: LOW OIL PRESSURE <sup>EA</sup>	61
210	FAULT 23h: HIGH OIL PRESSURE <sup>EA</sup>	43
211	FAULT 23g: BOTH FUELS SELECT <sup>EA</sup>	21
212	FAULT 23f: FUEL SELECT OFF <sup>EA</sup>	38
213	FAULT 23e: AUX LIMIT #3 <sup>EA</sup>	19
214	FAULT 23d: HIGH LIMIT <sup>EA</sup>	42
215	FAULT 23c: LWCO <sup>EA</sup>	63
216	FAULT 23b: AUX LIMIT #2 <sup>EA</sup>	18
217	FAULT 23a: AUX LIMIT #1 <sup>EA</sup>	17
218	FAULT 22s: OTHER INTERLOCKS <sup>EA</sup>	74
219	FAULT 22r: AUX INTERLOCK #5 <sup>EA</sup>	16
220	FAULT 22q: AUX INTERLOCK #4 <sup>EA</sup>	15
221	FAULT 22p: AIRFLOW SWITCH <sup>EA</sup>	13
222	FAULT 22o: LOW GAS PRESSURE <sup>EA</sup>	59
223	FAULT 22n: HIGH GAS PRESSURE <sup>EA</sup>	41
224	FAULT 22m: ATOMIZING SW <sup>EA</sup>	14
225	FAULT 22k: LOW OIL TEMP <sup>EA</sup>	62
226	FAULT 22j: HIGH OIL TEMP <sup>EA</sup>	44
227	FAULT 22i: LOW OIL PRESSURE <sup>EA</sup>	61
228	FAULT 22h: HIGH OIL PRESSURE <sup>EA</sup>	43
229	FAULT 22g: BOTH FUELS SELECT <sup>EA</sup>	21
230	FAULT 22f: FUEL SELECT OFF <sup>EA</sup>	38
231	FAULT 22e: AUX LIMIT #3 <sup>EA</sup>	19
232	FAULT 22d: HIGH LIMIT <sup>EA</sup>	42
233	FAULT 22c: LWCO <sup>EA</sup>	63
234	FAULT 22b: AUX LIMIT #2 <sup>EA</sup>	18
235	FAULT 22a: AUX LIMIT #1 <sup>EA</sup>	17
236	FAULT 21s: OTHER INTERLOCKS <sup>EA</sup>	74
237	FAULT 21r: AUX INTERLOCK #5 <sup>EA</sup>	16
238	FAULT 21q: AUX INTERLOCK #4 <sup>EA</sup>	15
239	FAULT 21p: AIRFLOW SWITCH <sup>EA</sup>	13
240	FAULT 21o: LOW GAS PRESSURE <sup>EA</sup>	59
241	FAULT 21n: HIGH GAS PRESSURE <sup>EA</sup>	41
242	FAULT 21m: ATOMIZING SW <sup>EA</sup>	14

Table 22. 7800 SERIES Fault Codes. (Continued)

Fault Code (Reg 40001)	Fault Message (NOTE: FAULT n: is not in the Fault and Strings Code)	Fault String Code (Table 22)
243	FAULT 21k: LOW OIL TEMP <sup>EA</sup>	62
244	FAULT 21j: HIGH OIL TEMP <sup>EA</sup>	44
245	FAULT 21i: LOW OIL PRESSURE <sup>EA</sup>	61
246	FAULT 21h: HIGH OIL PRESSURE <sup>EA</sup>	43
247	FAULT 21g: BOTH FUELS SELECT <sup>EA</sup>	21
248	FAULT 21f: FUEL SELECT OFF <sup>EA</sup>	38
249	FAULT 21e: AUX LIMIT #3 <sup>EA</sup>	19
250	FAULT 21d: HIGH LIMIT <sup>EA</sup>	42
251	FAULT 21c: LWCO <sup>EA</sup>	63
252	FAULT 21b: AUX LIMIT #2 <sup>EA</sup>	18
253	FAULT 21a: AUX LIMIT #1 <sup>EA</sup>	17
254	FAULT 10z: OTHER PREIGN ILK <sup>EA</sup>	75
255	FAULT 10y: VALVE CLOSURE <sup>EA</sup>	109

## 7800 SERIES Burner Control Fault History Records

Table 23 describes the registers that are part of a fault history record. To determine the actual register address for a parameter within the record, add the register offset to the start address of the record.

Table 23. Fault History Record Format.

Offset	Parameter Name	Access	Format	Notes
0	Fault code	R	U16	See Table 22.
1	Fault String	R	U16	See Table 21.
2	Sequence State	R	U16	See Table 20.
3	First line message	R	U16	See Table 21.
4	Second line message	R	U16	See Table 21.
5	Sequence time	R	U16	Seconds.
6-7	Total cycles	R	U32	
8-9	Total hours	R	U32	

**For More Information**

The Honeywell Thermal Solutions family of products includes Honeywell Combustion Safety, Eclipse, Exothermics, Hauck, Kromschröder and Maxon. To learn more about our products, visit [ThermalSolutions.honeywell.com](http://ThermalSolutions.honeywell.com) or contact your Honeywell Sales Engineer.

**Honeywell Process Solutions**

Honeywell Thermal Solutions (HTS)  
1250 West Sam Houston Parkway  
South Houston, TX 77042  
[ThermalSolutions.honeywell](http://ThermalSolutions.honeywell)

® U.S. Registered Trademark  
© 2018 Honeywell International Inc.  
32-00110-05 M.S. Rev. 05-18  
Printed in United States

**Honeywell**