

# L91A,B,D Proportioning Pressuretrol<sup>®</sup> Controllers

## PRODUCT DATA



## APPLICATION

L91 Proportioning Pressuretrol<sup>®</sup> Controllers are Series 90 Modulating Pressure Controllers that provide direct control of modulating motors or valves used on automatic burners or steam heating systems.

## FEATURES

- Models available for pressure systems up to 300 psi (2068 kPa).
- May be used with steam, air, noncombustible gases, or other fluids noncorrosive to brass or phos-bronze (300 psi model) bellows.
- When used with steam boilers, a steam trap (siphon loop) is recommended.
- Wiper on controller potentiometer moves in response to pressure changes.
- L91D has two potentiometers for unison control of two motors.
- L91B,D models have adjustable proportioning (throttling) range to allow selection of desired pressure control range.
- Adjustments made with screws on case top.
- Large, easily-read scaleplates in both U.S. customary (oz/sq. in., psi, or in. Hg) and metric (kPa, MPa, or mm Hg) units.
- Steel case with clear plastic cover to observe pressure settings and potentiometer action.
- Fitting with 1/4 -18 NPT threads allows rapid installation.
- Surface mount with screws through knockout holes in case back.

## Contents

Application	1
Features	1
Specifications	2
Installation	5
Wiring	6
Checkout	8
Service Information	9



## SPECIFICATIONS

Table 1. Models available.

Operating Ranges <sup>a</sup>			Proportioning (Throttling) Range at Midscale				Maximum Surge Pressure	
Model	U. S. Customary Units	Metric Units	Potentiometer Part No. <sup>b</sup>	Adjustable	U. S. Customary Units	Metric Units	psi	kPa
L91A	0 to 15 psi	0 to 103 kPa	23176CB	No	0.5 psi	3.4 kPa 25	172	
	5 to 150 psi	0.03 to 1.03 MPa	23176CB	No	5 psi	0.03 MPa	225	1551
	10 to 300 psi <sup>b</sup>	0.07 to 2.07 MPa	23176CB	No	12 psi	0.08 MPa	350	2413
L91B	0 to 15 psi	0 to 103 kPa	23176CF	Yes	1.5 to 12 psi	10 to 83 kPa	25	172
	5 to 150 psi <sup>c</sup>	0.03 to 1.03 MPa	23176CB	Yes	5 to 23 psi	35 to 160 kPa	225	1551
	10 to 300 psi <sup>c</sup>	0.07 to 2.07 MPa	23176CB	Yes	12 to 48 psi	85 to 330 kPa	350	2413
	10 to 300 psi	0.07 to 2.07 MPa	23176CF	Yes	30 to 110 psi	0.21 to 0.76 MPa	350	2413
L91D	0 to 15 psi	0 to 103 kPa	23176CF	Yes	1.5 to 12 psi	10 to 83 kPa	25	172
	5 to 150 psi <sup>c</sup>	0.03 to 1.03 MPa	23176CF	Yes	13 to 52 psi	0.09 to 0.36 MPa	225	1551
	10 to 300 psi <sup>c</sup>	0.07 to 2.07 MPa	23176CF	Yes	30 to 110 psi	0.21 to 0.76 MPa	350	2413

### Models (Table 1):

L91A: Single potentiometer; nonadjustable proportioning range.

L91B: Single potentiometer; adjustable proportioning range.

L91D: Two potentiometers allow unison control of motors; adjustable proportioning range.

**Electrical Rating:** 24 Vac.

**Potentiometer Action:** Wiper moves toward W on pressure rise, toward B on pressure fall. Potentiometer is field replaceable.

**Potentiometer Resistance:** 140 ohms (nominal) for L91A, B, and D models.

**Pressure Sensing Element:** Brass bellows, 10-300 psi models phos-bronze bellows.

**Minimum Ambient Temperature:** 32° F (0° C)

**Maximum Ambient Temperature:** 150° F (66° C)

**Adjustment Means:** Screws on controller case top; knurled knob for main scale setting on 10 to 300 psi (0.07 to 2.07 MPa) models.

**Setpoint:** At low pressure end of proportioning (throttling) range.

**Main Scaleplate:** Marked in both U.S. customary (oz/sq. in, psi, or in. Hg) and metric (kPa, MPa, or mm Hg) units.

**Proportioning Range Scaleplate (L91B,D only):** Graduated from A to F with a MIN (minimum) value below A. (See Table 2 for the value of each division.)

**Mounting Means:** Fitting on bellows has 1/4 - 18 NPT threads (external on 0 to 16 oz/sq. in., 0 to 4 psi, and 0 to 15 psi models; internal on all other models) for mounting on a pipe or steam trap (siphon loop).

NOTE: Some models are available with 1/4 - 19 BSP-TR internal threads; see Table 1.

Also can be surface mounted by screws through two knockout holes in case back.

## ORDERING INFORMATION

When purchasing replacement and modernization products from your TRADELINE® wholesaler or distributor, refer to the TRADELINE® Catalog or price sheets for complete ordering number.

If you have additional questions, need further information, or would like to comment on our products or services, please write or phone:

1. Your local Honeywell Automation and Control Products Sales Office (check white pages of your phone directory).
2. Honeywell Customer Care  
1885 Douglas Drive North  
Minneapolis, Minnesota 55422-4386

In Canada—Honeywell Limited/Honeywell Limitée, 35 Dynamic Drive, Toronto, Ontario M1V 4Z9.

International Sales and Service Offices in all principal cities of the world. Manufacturing in Australia, Canada, Finland, France, Germany, Japan, Mexico, Netherlands, Spain, Taiwan, United Kingdom, U.S.A.

**Electrical Connections:** Internal screw terminals. Hole inside of case for 1/2 in. conduit.

**Dimensions:** See Fig. 1; see Fig. 2 for mounting steam trap (siphon loop).

**Weight:** 1 lb, 15 oz (0.88 kg).

**Finish:** Gray.

**Replacement Parts:**

129178 Thermoplastic Cover.  
 23176CB Potentiometer: For all L91A models and a few L91B models (see Table 1); 140 ohms (nominal); length of active winding is 7/64 in. (2.8 mm).

23176CF Potentiometer: For all L91D models and most L91B models (see Table 1); 140 ohms (nominal); length of active winding is 1/4 in. (6.4 mm).

**Accessories:**

50024585-001 Steam Trap (siphon loop): 1/4 in. brass pipe with 1/4 -18 NPT external threads on both ends.  
 14026 Steam Trap (siphon loop): 1/4 in. steel pipe with 1/4 -18 NPT external threads on both ends.  
 33312B Knurled Adjustment Knob: With setscrew; fits on main scale pressure adjusting screw.  
 4074BWJ Limit Stop Assembly: To limit setpoint ranges; includes 129564 Range Stop 107194 Range Stop Screw, and 23466 Wrench.

**Table 2. Approximate value of each division (A to B, B to C, etc.) on proportioning (throttling) range scaleplate (L91B,D,F only)**

Operating Range		Value of Each Division	
U.S. Customary Units	Metric Units	U.S. Customary Units	Metric Units
0 to 10 oz/sq in.	0 to 7 kPa	6.2 oz/ sq in.	2.7 kPa
0 to 15 psi	0 to 103 kPa	1.8 psi	12.4 kPa
5 to 150 psi (L91B)	0.03 to 1.03 MPa	7.8 psi	0.054 MPa
5 to 150 psi (L91D)	0.03 to 1.03 MPa	6.7 psi	0.046 MPa
10 to 300 psi (L91B with 7/64 in. potentiometer)	0.07 to 2.07 MPa	16.4 psi	0.113 MPa
10 to 300 psi (L91B,D with 1/4 in. potentiometer)	0.07 to 2.07 MPa	13.8 psi	0.095 MPa

L91A,B,D PROPORTIONING PRESSURETROL® CONTROLLERS

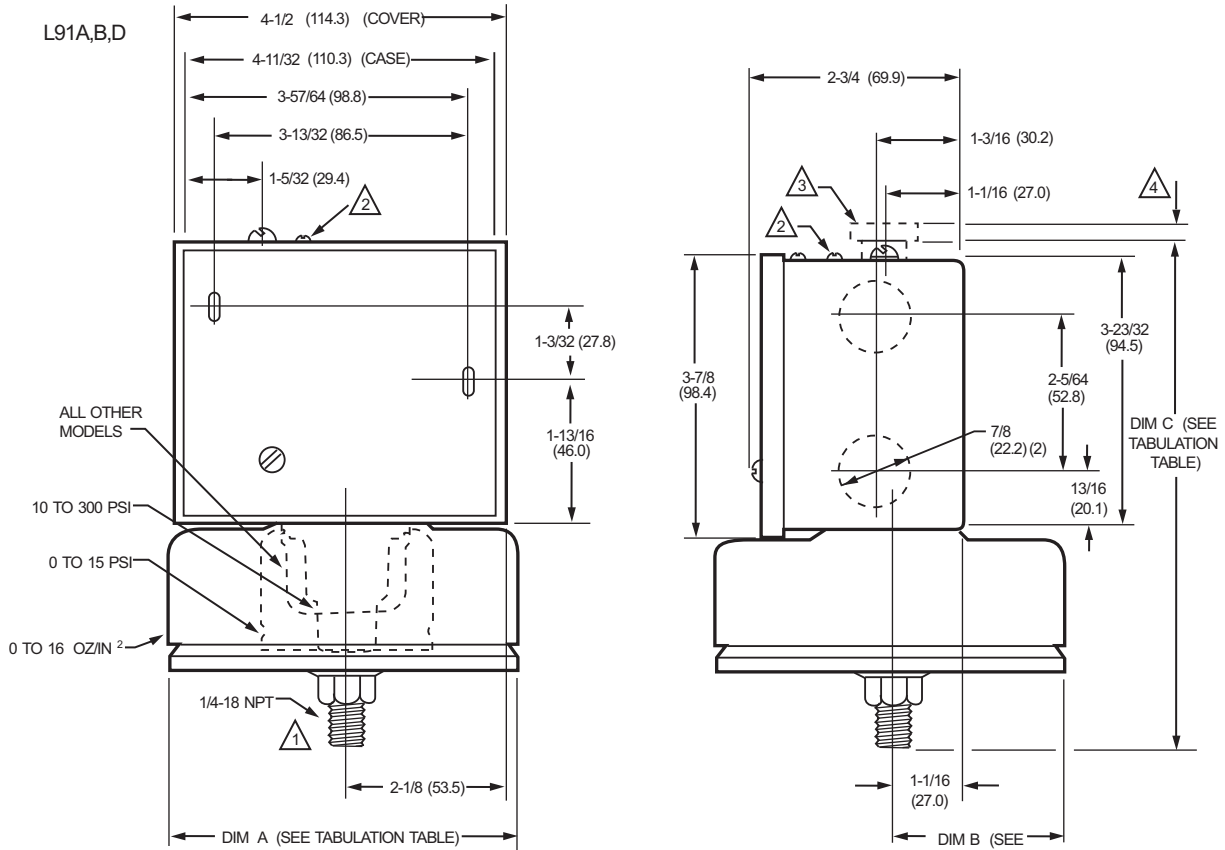

- 1 EXTERNAL THREADS ON 0 TO 15 PSI MODELS; INTERNAL THREADS ON ALL OTHER MODELS. SOME MODELS ARE ALSO AVAILABLE WITH 1/4-19 BSP-TR INTERNAL THREADS; SEE TABLE 1.
- 2 PROPORTIONING RANGE ADJUSTING SCREW ON L91B,D MODELS ONLY.
- 3 33312B KNURLED ADJUSTMENT SCREW KNOB, 7/8 IN. [22.2 MM] DIAMETER. KNOB IS INCLUDED WITH 10 TO 300 PSI [0.07 TO .07 MPa] MODELS; OPTIONAL ACCESSORY FOR OTHER MODELS.
- 4 FOR 10 TO 300 PSI [0.07 TO 2.07 MPa] MODELS. DIM C INCLUDES THE KNURLED ADJUSTMENT KNOB.

TABULATION OF DIMENSIONS A, B, AND C

OPERATING RANGE		DIM A		DIM B		DIM C	
CUSTOMARY UNITS	METRIC UNITS	IN.	MM	IN.	MM	IN.	MM
0 TO 15 PSI	0 TO 103 kPa	2-7/16	61.9	1-7/32	31.0	6-7/8	174.6
5 TO 150 PSI	0.03 TO 1.03 MPa	1-5/8	41.3	13/16	20.6	5-3/4	146.1
10 TO 300 PSI	0.07 TO 2.07 MPa	1-1/4	31.8	5/8	15.9	6-1/16 <sup>4</sup>	154.0 <sup>4</sup>

M29781

Fig. 1. Mounting dimensions of the L91 Proportional Pressuretrol® Controllers, in in. (mm).

## INSTALLATION

### When Installing This Product...

1. Read these instructions carefully. Failure to follow them could damage the product or cause a hazardous condition.
2. Check the ratings given in the instructions and on the product to make sure the product is suitable for your application.
3. Installer must be a trained, experienced service technician.
4. After installation is complete, check out product operation as provided in these instructions.

### **!** WARNING

#### Electrical Shock Hazard.

#### Can cause severe injury, death or property damage.

1. Disconnect power supply before beginning installation to prevent electrical shock and equipment damage.
2. When using the controller with a compressor, install a dampening device (such as a needle valve, header, or surge tank) to dampen pulsations that can damage the controller or reduce its life.

#### IMPORTANT

1. Locate the controller where the ambient temperature will not exceed 150° F (66° C).
2. When the controller is used on a boiler, be sure to connect a steam trap (siphon loop) between the controller and the boiler.
3. Before installing controller, be sure the siphon loop has enough water in it to fill lower trap.
4. Use pipe compound sparingly to avoid clogging the hole in the pipe or bellows fitting.
5. Do not tighten the controller by hand by holding onto the case and turning it.

### Location and Mounting

When used with steam boilers, always mount the controller above the water line in the boiler. A steam trap (siphon loop) must always be connected between the controller and the boiler (Fig. 2) to prevent boiler scale and corrosive vapors from attacking the bellows. Before installing controller, be sure the siphon loop has enough water in it to fill lower trap.

The controller can be mounted (1) beside the pressure gauge, (2) in a fitting on the boiler provided by the manufacturer, or (3) at a remote location in case of excessive vibration.

Make all pipe connections in accordance with approved standards. Use only a small amount of pipe compound to seal the connection joints. Excess pipe compound may clog the small hole in the fitting and prevent the controller from operating properly.

To avoid leaks and damage to the case, use a parallel jaw wrench on the controller fitting. Do not tighten the controller by hand by holding onto the case and turning it.

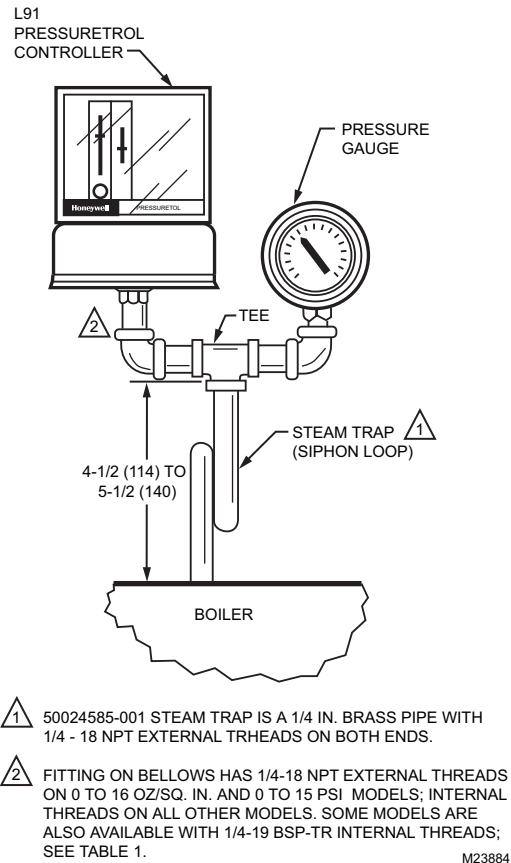

1 50024585-001 STEAM TRAP IS A 1/4 IN. BRASS PIPE WITH 1/4 - 18 NPT EXTERNAL TRHEADS ON BOTH ENDS.

2 FITTING ON BELLOWS HAS 1/4-18 NPT EXTERNAL THREADS ON 0 TO 16 OZ/SQ. IN. AND 0 TO 15 PSI MODELS; INTERNAL THREADS ON ALL OTHER MODELS. SOME MODELS ARE ALSO AVAILABLE WITH 1/4-19 BSP-TR INTERNAL THREADS; SEE TABLE 1.

M23884

**Fig. 2. Approximate dimensions in in. (mm) for mounting L91 Pressuretrol® Controller beside Pressure Gauge on Steam Trap (Siphon Loop).**

### Mounting Beside a Pressure Gauge

To mount the controller beside a pressure gauge (Fig. 2), remove the gauge. In its place, install a steam trap (siphon loop) with a tee on top. Using elbows and pipe nipples, mount the controller and pressure gauge on the ends of the tee.

### Mounting on a Boiler

If it is not convenient to mount the controller beside the pressure gauge, install a steam trap (siphon loop) in the fitting provided by the boiler manufacturer. If there is no fitting, mount the steam trap at a location recommended by the boiler manufacturer. Screw the controller directly to the steam trap, if possible.

### Mounting at a Remote Location

If there is excessive vibration at the boiler that may adversely affect the operation of the controller, mount the controller at a remote location. All piping from the boiler must be suitable and solidly mounted. The piping must be properly pitched to drain all condensation back to the boiler. If this causes the controller to be located at an inconvenient height (on large boilers), it may be mounted at a lower level if the connecting piping is filled with clean water. A steam trap (siphon loop) must be mounted between the remote piping and the controller.

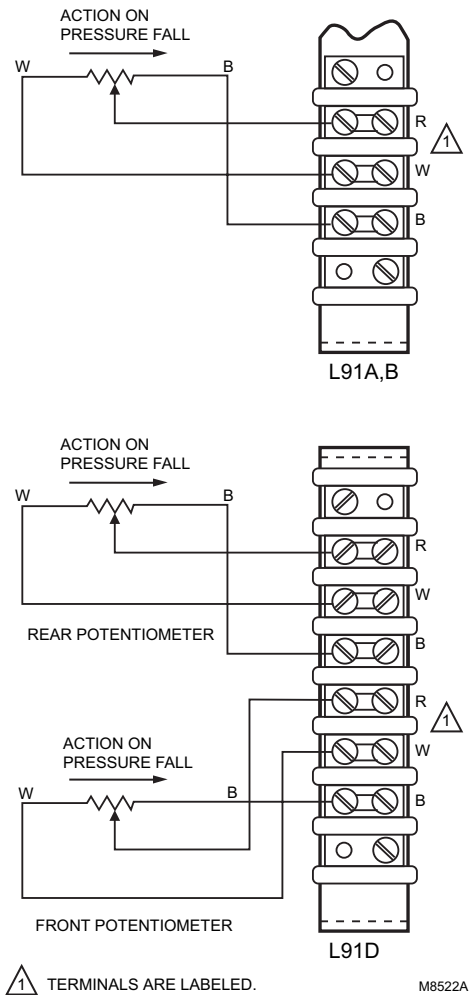

Fig. 3. L91 terminal blocks and internal schematics.

## WIRING

1. Disconnect power supply before beginning installation to prevent electric shock and equipment damage. All wiring must comply with applicable electrical codes, ordinances, and regulations. Use NEC Class 1 (line voltage) wiring.
2. For normal installation, use moisture-resistant No. 14 wire suitable for at least 167°F (75°C) if you are using the controller with a flame safeguard primary control, or at least 194°F (90°C) if you are using it with a programming control.
3. For high temperature installations, use moisture-resistant No. 14 wire, selected for a temperature rating above the maximum operating temperature.
4. Disconnect the power supply before beginning wiring to prevent electrical shock and equipment damage.
5. All models have a terminal block inside the cover (Fig. 3) and two 7/8 in. (22.2 mm) holes in one side for 1/2 in. conduit, cable, or wires. Remove the front cover by loosening the screw at the bottom of the scaleplate.

6. Refer to Fig. 4 for typical hookup. W and B connections may be interchanged at the motor for reverse action (cooling). Follow the burner or boiler manufacturer's wiring diagram if provided. Also refer to the wiring diagrams in the motor instructions.
7. Replace the front cover when wiring is completed.

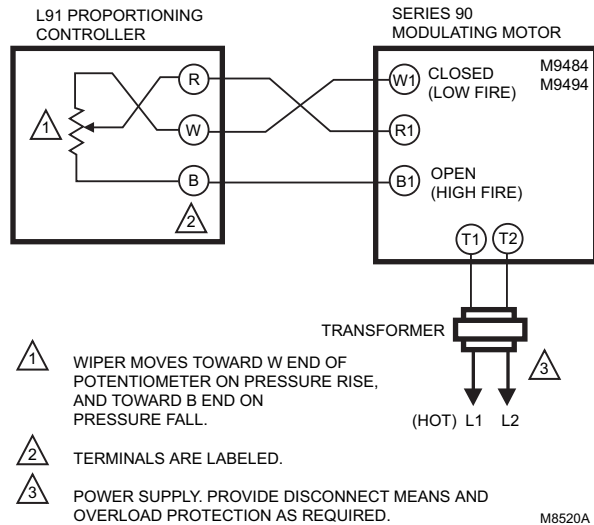

Fig. 4. Hookup of L91 Proportioning Pressuretrol® Controller to Series 90 Modulating Motor.

## Setting

In all models, the proportioning range (also called throttling range) extends above the main scale setpoint (Fig. 5). The proportioning range is fixed on L91A models, but is adjustable on L91B,D models. (For values, refer to Table 1 in the Specifications section.)

### Main Scale Set Point (All models)

Adjust the main scale setpoint for the desired operating pressure by turning the main scale adjusting screw (Fig. 7) or knurled adjustment knob on 10 to 300 psi (0.07 to 2.07 MPa) models, on the top of the case, until the main scale setting indicator is at the minimum pressure desired. The proportioning range extends above this value. The scaleplate is marked in both customary (oz/sq in., psi, or in. Hg) and metric (kPa, MPa, or mm Hg) units.

### Use of L91 Proportioning Controller with Limit Controllers

The L91 main scale setpoint plus the value of the differential (proportioning range) must be less than or equal to the limit controller's (L404) main scale setpoint.

For example, to control system pressure between 70 and 80 psi: select an L91B, 5-150 psi operating range, adjustable differential (proportioning, throttling range) of 5 to 23 psi and an L404A, 10-150 psi, adjustable differential of 8 to 16 psi. Set the L404A main scale setpoint at 80 psi and its adjustable differential at 10 psi. The L404A settings will then provide boiler pressure limit control between 70 and 80 psi. An L91B differential (proportioning range) pressure of 5 psi is desired. Therefore, an L91B main scale setpoint of between 70 and 75 psi is required (L91 main scale setpoint plus its differential must be less than or equal to the limit controller main scale set

point). The L91B settings provide system modulation between 70 and 75 psi or between 75 and 80 psi, depending on the exact setting of the L91B main scale setpoint.

Due to device tolerances, the scaleplate settings are approximate and, therefore, the settings should be fine-tuned with the system operating.

### Proportioning Range (L91B,D Only)

Adjust the proportioning range (throttling range) by turning the proportioning range adjusting screw (Fig. 6) on the top of the case until the proportioning range setting indicator is at the desired value. The proportioning range scale is graduated from A to F with a MIN (minimum) value below A. The value of each division depends on the operating range of the controller. Refer to Table 2 in the Specifications section.

### Typical Operation

Pressure variations cause the bellows to expand or contract. Linkage between the bellows and the potentiometer wiper causes the wiper to move across the potentiometer windings. This varies the resistance between R and B, and between R and W, causing an unbalance in the circuit connected to the controller. See Fig 7.

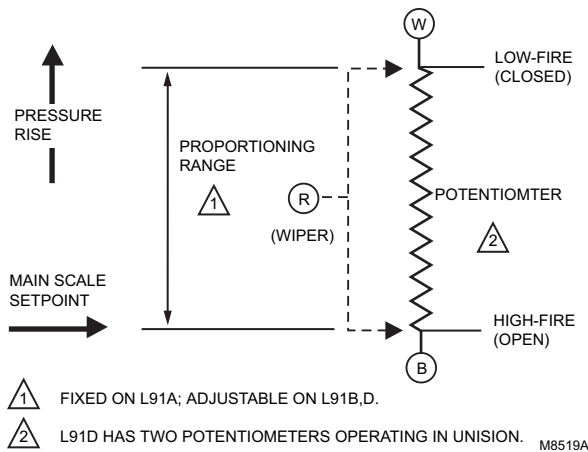
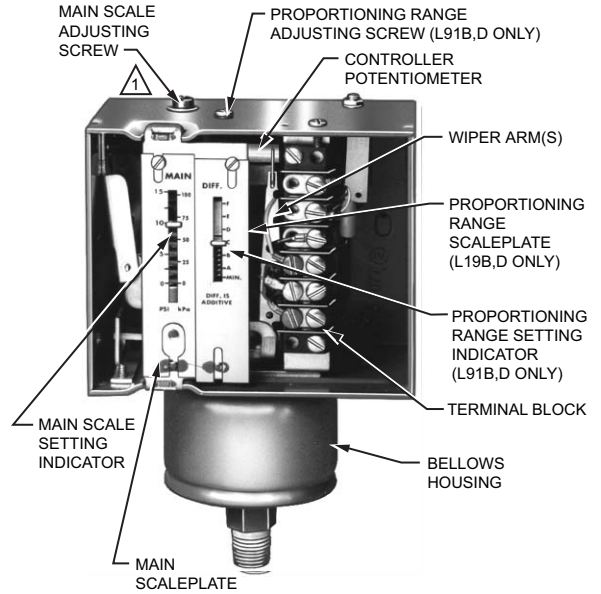

Fig. 5. L91A,B,D operating points.



1 KNURLED ADJUSTMENT KNOB ON 10 TO 300 PSI [0.07 TO 2.07 MPa] MODELS.

M8525

Fig. 6. Setting L91 Proportioning Pressuretrol® Controller.

A proportioning controller is used most often to regulate the firing rate of a burner by controlling a modulating motor (Fig. 4) or a modulating valve. The controller potentiometer, the feedback potentiometer in the motor (or in the valve actuator), and a balancing relay in the motor (or actuator) form an electric bridge circuit. As long as the pressure of the controlled medium remains at the setpoint of the controller, the circuit is balanced; that is, equal the relay contacts are open. When the circuit is balanced, the motor (or actuator) does not run.

If the pressure of the medium rises, the wiper in the controller moves toward W. This unbalances the circuit, so a larger current flows through one side of the balancing relay. The close contacts in the relay make, causing the motor (or valve actuator) to drive toward its closed position. As the motor (or actuator) runs, the wiper on the feedback potentiometer moves in a direction to balance the circuit. When the circuit is again in balance, the balancing relay contacts open and the motor (or actuator) stops. The valves and dampers connected to the motor or actuator will be partially closed, decreasing the firing rate and reducing the pressure.

Similarly, if the pressure of the controlled medium falls, the wiper on the controller potentiometer moves toward B, and the open contacts in the balancing relay make. The motor (or actuator) drives toward its open position until circuit balance is achieved. The valves and dampers will be opened wider and the firing rate will increase, thus increasing the pressure.

A small change in the pressure of the controlled medium will cause a change in the firing rate to compensate for it, thus keeping the pressure constant. This process is called modulation.

## CHECKOUT

After the controller is installed, wired, and set, it should be tested with the system in operation. First, allow the system to stabilize. Then, observe the operation of the controller while raising and lowering its setpoint. Pressure should increase when the setpoint is raised and decrease when the setpoint is lowered. Use accurate pressure testing equipment when checking out the controller. Do not rely on inexpensive gauges. The controllers are carefully calibrated at the factory.

Make sure the modulating motor or modulating valve actuator reaches the low- and high-fire positions at the proper points. If the motor or actuator runs in the proper direction when the setpoint is adjusted, assume that the controller is operating properly. If it runs in the wrong direction, reverse the B and W wires. Observe the action of the motor or actuator until it stabilizes. If the motor or valve is moving constantly, widen the proportioning range (not adjustable on an L91A) incrementally until the system is stable.

### If a Controller Seems to Operate Improperly

If the controller is suspected of operating improperly, it may be further checked by:

1. Leaving the controller installed where it is, but disconnecting all power to the controller motor or valve.
2. Loosening the cover screw below the main scaleplate and removing the cover.
3. Disconnecting the wires from the controller.
4. Connecting an ohmmeter between controller terminals B and W to measure the resistance for the potentiometer in the controller. The ohmmeter should read about 135 ohms for an L91A,B, or D.
5. Connecting the ohmmeter between controller terminals W and R (Fig. 8) and raising the setpoint of the controller above the actual pressure being measured. The ohmmeter should read the full value of the potentiometer measured in step 4 (135 ohms for an L91A,B, or D).
6. Slowly lowering the setpoint of the controller while observing the ohmmeter reading. The resistance should drop to zero at some setpoint below the actual pressure.
7. Making an approximation of the proportioning range by observing the change in setpoint required for a resistance change from zero to full value.
8. When the controller is operating properly, reconnecting the wires, replacing the cover, tightening the cover screw, and resetting the controller to the desired value.
9. Reconnecting power to the controlled motor or valve.

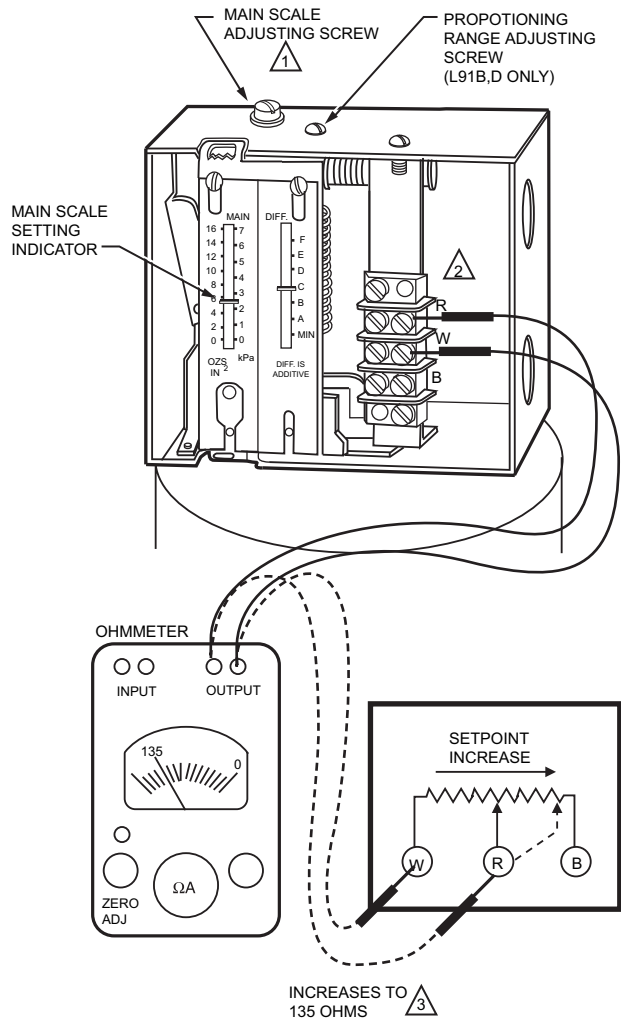

- INCREASES TO 135 OHMS (3)
1. KNURLED ADJUSTMENT KNOB ON 10 TO 300 PSI [0.07 TO 2.07 MPA] MODELS.
  2. TERMINALS ARE LABELED
  3. 135 OHMS ON L91A,B OR D.

M8546A

Fig. 7. Checking L91 Proportioning Pressuretrol® Controller.



## CAUTION

**Equipment Damage Hazard.**

**Failure to follow checkout instructions can damage components or systems.**

Do not put the system into service until you have satisfactorily completed all applicable tests described in this Checkout section, all tests in the Checkout section of the applicable instructions, all tests for the flame safeguard control, and any tests required by the burner and boiler manufacturers.

## SERVICE INFORMATION



### CAUTION

#### Electrical Shock Hazard

1. Only qualified service technicians should attempt to service or repair flame safeguard controls and burner systems.
2. Disconnect power supply before cleaning the potentiometer windings or wiper, or before replacing the controller potentiometer.

## Calibration

All controllers are carefully tested and calibrated at the factory under controlled conditions. If the actual operating pressure does not match the setpoint, move the main scaleplate slightly up or down until the setpoint agrees with the actual pressure.

## Maintenance

Keep the cover of the controller in place at all times to protect the internal components from dirt, dust, and physical damage. Perform routine maintenance occasionally by inspecting and blowing or brushing away any accumulated dirt and dust. To assure proper functioning of the controller at all times, perform an operational check of the entire system during routine maintenance checks. Be sure to handle controllers carefully at the time of installation, during actual use, and during maintenance.

## Cleaning the Potentiometer Windings or Wiper

Occasionally, the windings or wiper on the potentiometer (two on the L91D) may need cleaning. Disconnect the power supply before removing the cover from the controller and before cleaning the potentiometer.

#### IMPORTANT

1. Use an electrical contact cleaner that does not contain solvents.
2. Use extreme care to avoid bending the wiper arm, changing the wiper tension and damaging the potentiometer windings.
3. Do not use an abrasion or burnishing tool to clean the potentiometer windings or wiper.
4. Do not use hard paper, such as a business card, or abrasive materials (sandpaper, emery boards, file, etc.) to clean the windings or wiper.

Solvent-type electrical contact cleaners can deteriorate plastic components and wire insulation and leave an oily residue that accumulates particulate matter (dust, etc.). The residue can break down to form various carbonaceous substances that cause early potentiometer failure.

Use of abrasive materials results in wearing of the potentiometer windings and accumulation of particulate matter that changes the resistance between the windings and the wiper.

## Replacing the Controller Potentiometer (Fig. 8–10)

#### IMPORTANT:

1. Replace the controller potentiometer only when necessary to obtain proper operation.
2. When replacing the potentiometer, be very careful not to bend or damage the wiper arm, and not to change the wiper tension. Any damage or change in tension will decrease the life of the new potentiometer.

1. Disconnect all power to the controller.
2. Loosen the cover screw below the main scaleplate and remove the cover.
3. Mark the wires to the external device (motor or valve actuator) and disconnect them from the terminal block.
4. Remove the screw holding the terminal block bracket to the top of the case (Fig. 8). Put this screw in a safe place because it will be needed later.
5. While careful not to damage the potentiometer wiper or any of the internal wiring, lift out the terminal block and bracket.
6. Before removing any potentiometer wires, carefully note and record (sketch) the position (off-center) of the active winding on the potentiometer and the location and connections of all wiring terminals. The new potentiometer must be inserted and connected the same.

Example: In Fig. 9, the active winding is on the left half of the potentiometer; the wire from the left end of the winding is connected to the (W) terminal on the terminal block, and the wire from the right end of the winding is connected to the (B) terminal on the terminal block.

7. Loosen the (W) and (B) screws on the terminal block, and remove the two wires to the active winding of the potentiometer. Leave the wire to the wiper arm intact.
8. Carefully unscrew the bolt that holds the potentiometer to the bracket. Make sure the potentiometer wires do not entangle with the wiper and bend it.
9. Carefully slide the old potentiometer off the bolt.
10. Carefully slide the bolt through the new potentiometer. Make sure that:
  - a. The off-center position of the winding on the new potentiometer is the same as the old potentiometer. (Consult sketch in step 6.)
  - b. The wiper will contact bare wires. (Rotate the potentiometer on the bolts so the surface of the winding where the brown enamel was removed is toward you.)
11. Screw the bolt into the potentiometer bracket. Make sure the wiper is contacting bare wires (step 10.b); then tighten the bolt.
12. Connect the two potentiometer wires to the (W) and (B) terminals on the terminal block and tighten the screws. Make sure these wires are connected to the same terminals as in the old potentiometer. (Consult sketch in step 6.)
13. Carefully fit the hole in the bottom of the terminal block bracket over the screw protruding upward from the bottom of the case (Fig. 10). Insert the screw (removed in step 4) through the hole in the top of the case (Fig. 8) and into the top of the bracket, and tighten it.
14. Reconnect the wires from the external device (motor or actuator) to the terminal block.
15. Replace the cover and tighten the cover screw.
16. Reconnect power to the controller.

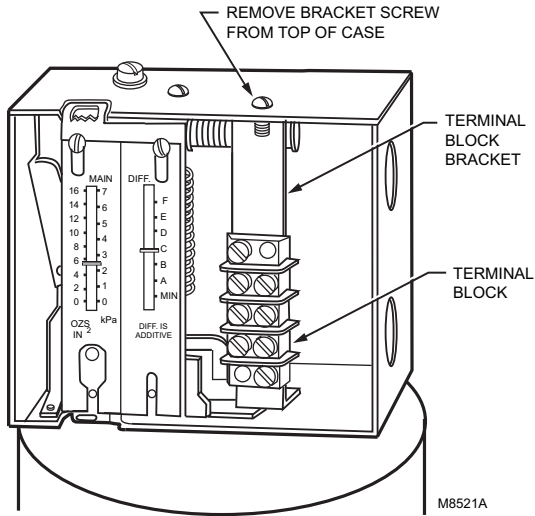

Fig. 8. Removing terminal block bracket.

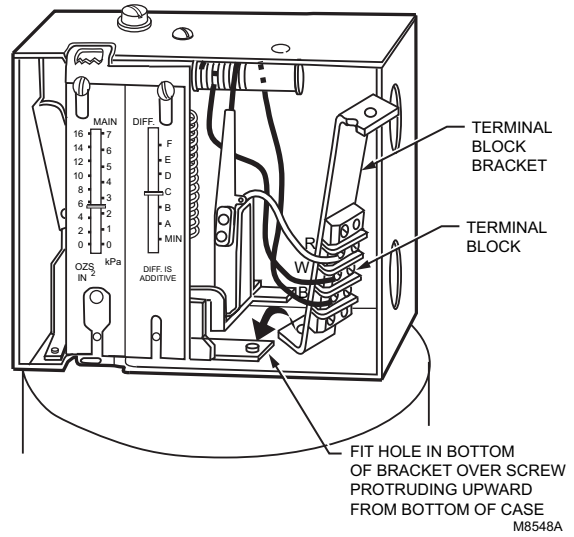
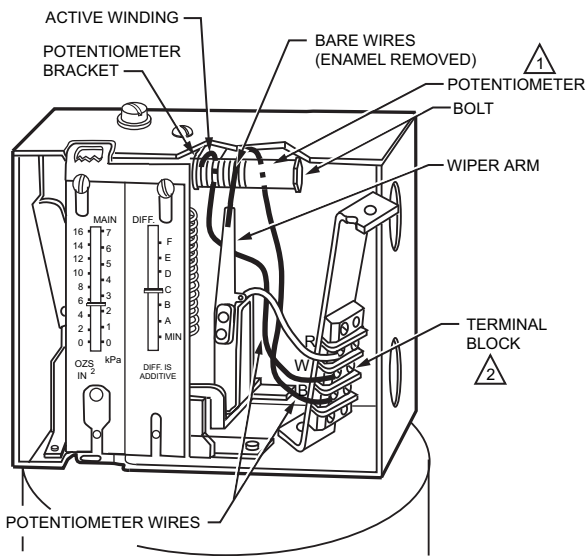

Fig. 10. Replacing terminal block bracket.



1 THE POTENTIOMETER IN AN L91A IS MOUNTED AT A 45 DEGREE ANGLE INSTEAD OF HORIZONTALLY. AN L91D HAS TWO POTENTIOMETERS.

2 TERMINALS ARE LABELED.

M8547A

Fig. 9. Replacing potentiometer in L91.



**Automation and Control Solutions**

Honeywell International Inc.  
1985 Douglas Drive North  
Golden Valley, MN 55422

Honeywell Limited-Honeywell Limitée  
35 Dynamic Drive  
Toronto, Ontario M1V 4Z9  
[customer.honeywell.com](http://customer.honeywell.com)

® U.S. Registered Trademark  
© 2009 Honeywell International Inc.  
60-2152—08 K.K. Rev. 12-09  
Printed in U.S.A.

**Honeywell**