

GAS PRESSURE SWITCHES TYPE PG..

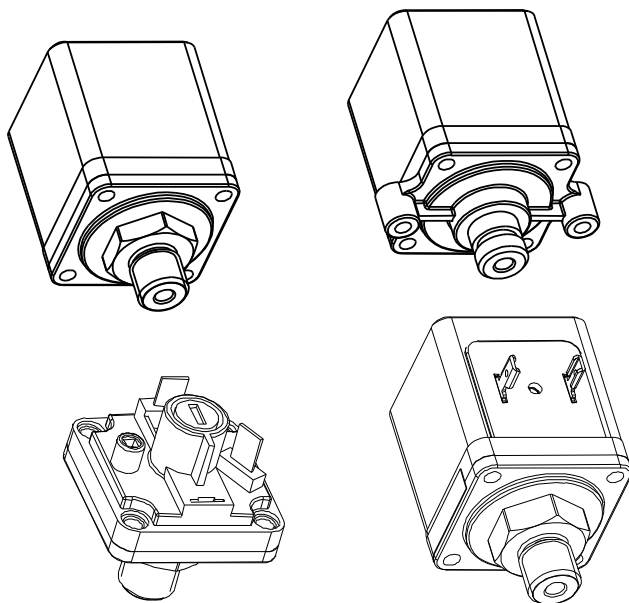

APPLICATION

The gas pressure switches of this series are available with both fixed and adjustable switching pressure setting. They are particularly suitable for use in all atmospheric and fan assisted gas burners and, more generally, in any application requiring gas pressure range control.

MANUFACTURING FEATURES

Pressure switches consist of a quick switching system operated by a membrane acting as a pressure signal transducer, fixed on a brass frame allowing to mount the pressure switch on a valve or on the gas piping. From the electrical point of view, two 6,3x0,8mm male fast-on contacts are available for the use of the device as a switch in series to the thermostat line (Fig.1). This pressure switch shall be connected to earth by means of the mechanical connection.

Pressure switches are manufactured with two different fixing systems:

- male clutch with G 1/4" thread (Fig.3);
- bracket with sealing O-ring and two M4 screws (Fig.2) to fit pressure switches to BRAHMA valves of the EG... series.

Fig.2 and Fig.3 show the overall dimensions.

Pressure switches are equipped with a transparent plastic cover which protects the electrical connections and enables to read the setting in adjustable versions; these devices must be connected to earth by means of a mechanical connection.

TECHNICAL FEATURES

Pressures values for fixed setting version (*) :

Trip point: 9 ±2 mbar

Reset point: trip point -3 ± 0.75 mbar

Pressure range for adjustable setting version:

5 ÷45mbar

Hysteresis: 3 mbar

Max. working pressure: 500mbar

Electrical connections: AMP 6,3x0,8 mm (DIN46244)

- Plug DIN43650

Voltage rating: 250 Vac

Contact rating (AgNi contact): 6 A (resistive load)

- 1.5 A (inductive load)

Diaphragm: nitrile rubber (NBR)

Ambient temperature range: 0°... 85 °C

Protection degree: With cover: IP40

- Without cover: IP00

Mounting position: any

Mechanical connection: UNI ISO 228/1 G1/4"

Fitting to gas valves of the EG Series by means of M4 screw

(*) Versions with different pressure setting are available on request.

APPROVAL

Pressure switches are in compliance with the standard EN 1854:2010.

- EU- type certification in accordance with the new European Gas Appliances Regulation (EU) 2016/426 (PIN 0063BL4664);
- Conformity to EC Low-voltage directive 2014/35/EU

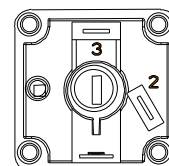

Fig. 1

DIRECTIONS FOR INSTALLATION AND MAINTENANCE

- This gas pressure switch is a safety appliance and should not be modified. The manufacturer's responsibility and guarantee are invalidated in case the device is tampered with by the user.
- The applicable national regulation and European standards (Ex. EN 60335-1 and EN 60335-2-102) related to the electrical safety must be respected;
- During the assembly of the gas pressure switch to the system pipes, avoid twisting the plastic parts, but always use a hexagonal wrench to be fitted to the body.
- Make sure that the max. fuel input pressure never exceeds the value appearing on the label.
- All operations (installation, maintenance, etc.) must be carried out by a qualified technician.
- Before any connection operation, completely isolate the system from power supply (multi-pole disconnection). Place the system safely to avoid accidental switch-on and make sure there is no voltage. If the system is not switched off, there is a risk of electric shock.
- During and after any operation (installation, maintenance, etc.), make sure that the type and code are the ones provided, check the correct functioning and the internal and external thickness of the gas pressure switch.
- In the event of a fall or impact, the gas pressure switches must not be started, as safety functions may be compromised even if no damage is visible to the outside.
- Faulty gas pressure switches or damaged must be unplugged from power supply and cannot be used.
- The gas pressure switch has a designed lifetime* based on the endurance tests in the standard EN 1854:2010. A summary of the conditions has been published by the European Control Manufacturers Association (Afecor) (www.afecor.org). The designed lifetime is based on use of the gas pressure switch according to the manufacturer's technical notes. After reaching the designed lifetime in terms of the number of burner startup cycles, or the respective time of usage, the gas pressure switch has to be replaced by authorized personnel.

* The designed lifetime is not the warranty time specified in the Terms of Delivery

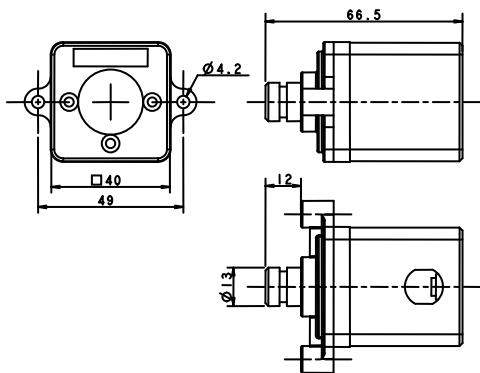

Fig. 2 Bracket fixing system

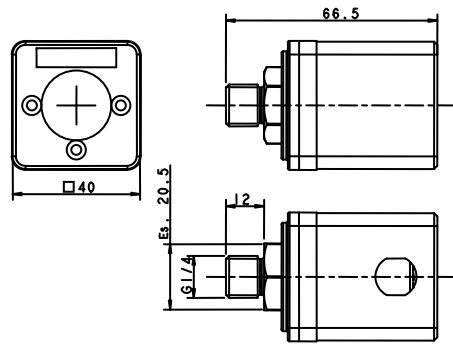

Fig. 3 G1/4 threaded male fixing system

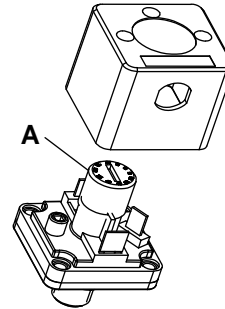

Fig. 4

DIRECTIONS FOR SWITCHING PRESSURE ADJUSTMENT - for adjustable version only

To adjust the pressure value enabling the switching of the device contacts, take off the protection cover by removing the fixing screw.

By means of the central knob (see Fig.4), the threshold pressure can be adjusted within the preset operating range of each pressure switch.

For an accurate switching pressure setting, it is advisable to use a pressure gauge.

CAUTION

Before adjusting the pressure setting in adjustable versions, cut off the supply voltage in the final appliance in which the device is installed.

PRODUCT DESIGNATIONS

- PGF: gas pressure switches with fixed setting with UNI ISO 228/1 G1/4" threaded fixing system.
- PGF-F: gas pressure switches with fixed setting with UNI ISO 228/1 G1/4" threaded fixing system, with connection plug DIN43650.
- PGR: gas pressure switches with adjustable setting with UNI ISO 228/1 G1/4" threaded fixing system.
- PGR-F: gas pressure switches with adjustable setting with UNI ISO 228/1 G1/4" threaded fixing system, with connection plug DIN43650.
- PGFV: gas pressure switches with fixed setting for fitting to Brahma gas valves.
- PGRV: gas pressure switches with adjustable setting for fitting to Brahma gas valves.



NOTES FOR PRODUCT DISPOSAL

The device contains electronic components and cannot therefore be disposed of as normal household waste. For the disposal procedure, please refer to the local rules in force for special waste.

ATTENTION --> Company Brahma S.p.A. declines any responsibility for any damage resulting from Customer tampering with the

BRAHMA S.p.A.
 Via del Pontiere, 31
 37045 Legnago (VR)
 Tel. +39 0442 635211 - Telefax +39 0442 25683
[http:// www.brahma.it](http://www.brahma.it) E – mail: brahma@brahma.it

10/10/18 Subject to amendments without notice